

**D20-series Compact
Digital Positioner**

FCD PNENIM0020-07-A5 – 01/26

*Installation
Operation
Maintenance*



Contents

| | | | |
|---|-----------|---|-----------|
| 1. Introduction..... | 3 | 11. Maintenance/service | 47 |
| 2. Warning..... | 4 | 11.1 Disassembling D20 | 47 |
| 3. Storage..... | 6 | 11.2 Circuit boards (PCB) | 48 |
| 4. Unpacking | 6 | 11.3 Limit Switches | 49 |
| 5. Description..... | 7 | 11.4 Valve block | 50 |
| 6. Principle of operation..... | 8 | 11.5 Potentiometer | 51 |
| 7. Type sign example | 9 | 12. Troubleshooting | 52 |
| 8. D20 Order code | 10 | 13. Technical data..... | 53 |
| 9. Installation | 11 | 14. Dimensional Drawing..... | 55 |
| 9.1 Mounting | 12 | 15. Spare parts | 56 |
| 9.2 Air Connection | 19 | 16. Declaration of Conformity..... | 58 |
| 9.3 Electrical connections | 20 | 17. Control Drawing | 59 |
| 9.4 Wiring and grounding guidelines | 23 | 18. Annex: Diagnostic Alarms..... | 61 |
| 9.5 Grounding Screws | 23 | 19. Contact List..... | 64 |
| 9.6 Electromagnetic compatibility | 24 | | |
| 9.7 Compliance voltage | 24 | | |
| 10. Control..... | 25 | | |
| 10.1 D20 Single push button | 25 | | |
| 10.2 D22 5 Push buttons | 29 | | |

1. Introduction

The D20-series is a digital positioner designed primarily for controlling modulating valves. The positioner can be used with single acting actuators with either rotary or linear movement.

The D20-series can be equipped with modules for limit switches and pressure gauges. The modules can be factory assembled before delivery or fitted later.

The modules for limit switches can contain one of the following:

- Two mechanical contacts
- Two proximity switches
- Two inductive sensors

See Page [20](#), [21](#) and [49](#) for more options available.



Note: *Only qualified technicians (according to IEC 60079 series of standards) are allowed to work with certified products.*

2. Warning



Special Conditions for Safe Use

The enclosure of PMV D20-series Intrinsically safe version is made of aluminum and any impact or friction caused by external objects shall be avoided in the application. Control Drawing D4-086C contains the parameters for intrinsic safety. The intrinsic safe circuits D20-series is insulated from earth and complies with the dielectric strength test of 500 V ac.

Special Conditions for Safe Use (ATEX/IEC specific)

The surface area of the plastic parts on the cover exceeds the limits specified in EN 60079-0 for II 1G (EPL Ga) for gas group IIC and intensive rubbing or brush charging should be avoided when used in an IIC explosive atmosphere.

In a hazardous environment where there is a risk of explosion, electrical connections must comply with the relevant regulations.

Do not disconnect equipment unless area is known to be non-hazardous. or; read, understand and adhere to the manufacturer's live maintenance procedures. To prevent ignition of flammable or combustible atmospheres, disconnect power before servicing,

Substitutions of components may impair suitability for hazardous (classified) locations.

Special Conditions for Safe Use (FM specific)

For Intrinsically Safe applications: Use linear barrier only.

Potential risk of sparking from aluminum alloy enclosure. In Division 1 or Zone 0 installations, equipment shall be installed in such manner as to prevent the possibility of sparks resulting from friction or impact against the enclosure.

Potential risk of electrostatic sparking. Clean only with a damp cloth.

Environmental requirements

Some switch options may decrease the temperature working range see Control Drawing D4-086C for details.



Maintenance/service

Warning!

When upgrading electronically parts inside a PMV positioner approved for installation in Hazardous locations special procedures apply, permission from PMV/Flowserve is required prior to the start of work. Please contact a Flowserve office for information regarding proper procedures. www.pmv.nu or infopmv@flowserve.com

Always turn off the air and electrical supplies before starting any work.

Always turn off the air and electrical supplies (input signals) when shutting down the PMV positioner for any purpose.

General safety

Safety instruction

Read the safety instructions in this manual carefully before using the product. The installation, operation, and maintenance of the product must be done by staff with the necessary training and experience. If any questions arise during installation, contact the supplier/sales office before continuing work.

Warning

The valve can open or close very quickly when in operation and, if handled incorrectly, may cause damages to fingers. There may also be unintentional effects due to it fully opening or shutting off the flow in the process pipe. Please note the following:

- If the input signal fails or is switched off, the valve operates quickly to its default position.
- If the compressed air supply fails or is turned off, rapid movements can occur.
- The valve is not controlled by the input signals when in the Out of Service mode. It will open/ close in the event of an internal or external leak.
- If a high value is set for Cut off, fast movements can occur.
- When the valve is controlled in the Manual mode, the valve can operate quickly.
- Incorrect settings can cause self-oscillation, which can lead to damage.

Important

- Always turn off the compressed air supply before removing or disconnecting the air supply connection or the integral filter. Remove or disconnect with care as air connection "C-" is still under pressure even after the air supply is turned off.
- Always work in an ESD (Electrostatic Discharge) protected area when servicing the Printed circuit boards (PCB's). Make sure the input signal is switched off.
- The air supply must be free from moisture, water, oil and particles according to DIN/ISO 8573-1-2001 3.2.3
- Failure to comply with instructions specified in this IOM leads to warranty void.

3. Storage

General

The D20-series positioner is a precision instrument. Therefore, it is essential that it is handled and stored in the correct way. Always follow the instructions in this IOM!

Note: As soon as the positioner is connected and started, internal air venting will provide protection against corrosion and prevent the ingress of moisture. For this reason, the air supply pressure should always be kept on unless repair/maintenance work of the positioner, actuator or valve equipment is in progress.

Storage indoors

Store the positioner in its original packaging. The storage environment must be clean, dry, and cool (-40°C to 80°C, -40°F to 176°F).

Storage outdoors or for a longer period

If the positioner must be stored outdoors, it is important that all the cover screws are tightened and that all open ports/connections are properly sealed and/or plugged.

The red shipping plugs are not intended as a permanent outdoor plug. The unit should be packed with a desiccant (silica gel) in a plastic bag or similar, covered with plastic, and not exposed to sunlight, rain, or snow.

4. Unpacking

Each delivery includes a packing slip. When unpacking, check all delivered valves and accessories using this packing slip. The packing slip shall match order.

Report transport damage to the carrier immediately.

In case of discrepancies, contact your nearest FLOWSERVE location.

5. Description

PMV D20-series is a compact digital positioner that suits both linear and rotary actuators. It's modular and flexible design allows mounting according to the both standard VDI/VDE 3845 for rotary and IEC 534-6 & Flowtop for linear actuators with integrated tubing.

Further on, PMV D20/D22 offers feedback capability with optional plug in switches, HART communication and auto calibration for simple and trouble free commissioning.



6. Principle of operation

The PMV D20 positioner is a digital positioner with various options. The positioner consists of three main modules:

1. The microprocessor-based electronic control module includes direct local user interface switches
2. The piezo valve-based electropneumatic converter module
3. The infinite resolution valve position sensor.

The basic positioner operation is best understood by referring to figure 1. The complete control circuit is powered by the two-wire, 4-20 mA command signal. The analog 4-20 mA command is passed to the microprocessor, where it is compared to the measured valve stem position. The control algorithm in the processor performs control calculations and produces an output command to the piezo valve, which drives the

pneumatic amplifier. The position of the pilot valve in the pneumatic amplifier is measured and relayed to the inner loop control circuit. This two-stage control provides for more responsive and tighter control than is possible with a single stage control algorithm. The pneumatic amplifier controls the airflow to the actuator. The change of pressure and volume of the air in the actuator causes the valve to stroke. As the valve approaches the desired position, the difference between the commanded position and the measured position becomes smaller and the output to the piezo is decreased. This, in turn, causes the pilot valve to close and the resulting flow to decrease, which slows the actuator movement as it approaches, the new commanded position. When the valve actuator is at the desired position. The pneumatic amplifier output is held at zero, which holds the valve in a constant position.

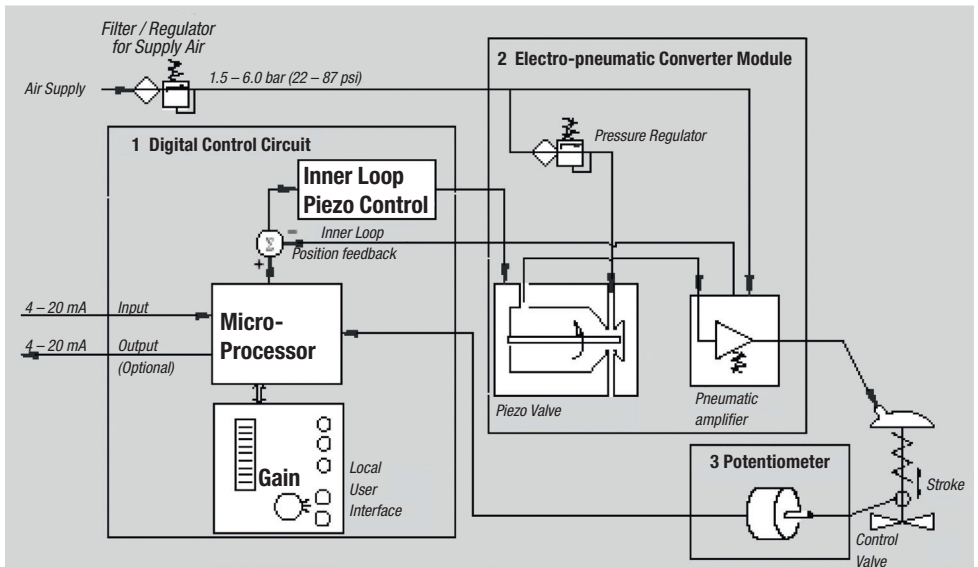

Figure 1

7. Type sign example

marking

no:

Ratings and Marking

D20 ATEX/IEC certification temperature range and marking:

II 1 G Ex ia IIC T4 Ta -20°C to 80°C Ga

Low temp version -40°C to 80°C

D20 US/CA FM certification FM18US0180X and FM18CA0082X marking:

IS Cl. I Div.1 Gr. A-D T4

Cl. I Zone 0 AEx/Ex ia IIC T4 Ga

Cl. I Div.2 Gr. A-D T4

Cl. I Zone 2 IIC T4 (US Only)

Listing Company :

PMV Automation AB

Korta Gatan 9

SE-171 54 SOLNA

SWEDEN

8. D20 Order code

| | | |
|--|---|---|
| A = Model no | | |
| D20 | Single button interface, LED status | <input type="checkbox"/> |
| D22 | Full LCD menu, 5 button UI, LED status | <input type="checkbox"/> |
| B = Approval, Certificate | | |
| D | General purpose version | <input type="checkbox"/> |
| A | Intrinsically Safe Ex ia ATEX | <input type="checkbox"/> |
| B | Intrinsically Safe Ex ia INMETRO | <input type="checkbox"/> |
| N | Intrinsically Safe Ex ia CCC | <input type="checkbox"/> |
| M | Intrinsically Safe Ex ia CCOE | <input type="checkbox"/> |
| E | Intrinsically Safe Ex ia IECEX | <input type="checkbox"/> |
| F | Intrinsically Safe Ex ia FM | <input type="checkbox"/> |
| C = Function | | |
| S | SA D20 E/P (poppet valve) | <input type="checkbox"/> |
| D = Connections Air, Electrical | | |
| M | 1/4" NPT air, M20x1,5 electrical | <input type="checkbox"/> |
| N | 1/4" NPT air, 1/2"NPT electrical | <input type="checkbox"/> |
| E = Connection feature | | |
| 22 | Electrical conduits | <input type="checkbox"/> |
| T2 | Electrical conduits, threaded Aux. ventilation | <input type="checkbox"/> |
| F = Housing material/ Surface treatment | | |
| U | Aluminum/Powder epoxy, black | <input type="checkbox"/> |
| G = Mounting options / Shaft | | |
| RM | Remote mounting (position sensing unit sold separately) | <input type="checkbox"/> |
| 09 | Double D type, adaptor spindle | <input type="checkbox"/> |
| 12 | Flowtop, direct mounting, D4-As909m(D20) included | <input type="checkbox"/> |
| 23 | VDI/VDE 3845 rotary, Mounting kit not included | <input type="checkbox"/> |
| 30 | Adaptor shaft, select between 01/06/26/30/36 | <input type="checkbox"/> |
| 39 | IEC 534-6, Flat D type, nut incl. Mounting kit not included | <input type="checkbox"/> |
| H = Cover and Indicator | | |
| PVA | PMV, Black cover, Arrow indicator | (Not when G=RM unit) <input type="checkbox"/> |
| PVB | PMV, Black cover, No indicator | <input type="checkbox"/> |
| FWA | Flowserve, White, Arrow indicator | (Not when G=RM unit) <input type="checkbox"/> |
| FWB | Flowserve, White, No indicator | <input type="checkbox"/> |
| I = Temperature/seals | | |
| Z | -20°C to 80°C (-4°F to 176°F) | <input type="checkbox"/> |
| Q | Low temp -40°C to 80°C (-40°F to 176°F) | <input type="checkbox"/> |
| J = Input signal/Protocoll | | |
| 4 | 4-20 mA / none | <input type="checkbox"/> |
| 5 | 4-20 mA, / HART | <input type="checkbox"/> |
| P | Profibus PA | (Only when D22) <input type="checkbox"/> |
| F | Foundation Fieldbus | (Only when D22) <input type="checkbox"/> |
| K = Feedback option, switches | | |
| X | No feedback option | <input type="checkbox"/> |
| T | 4-20 mA transmitter | (Only when J = 4,5) <input type="checkbox"/> |
| S* | Limit switches Mechanical SPDT | <input type="checkbox"/> |
| N* | NAMUR V3 type sensor, P+F NJ2-V3-N | <input type="checkbox"/> |
| P* | Limit switches Proximity SPDT | <input type="checkbox"/> |
| 5* | Slot type NAMUR sensor, P+F SJ2-SN | <input type="checkbox"/> |
| 6* | Slot type NAMUR sensor, P+F SJ2-N | <input type="checkbox"/> |
| L = Options, Add in electronics | | |
| 0 | No pressure sensors | <input type="checkbox"/> |
| M = Accessories | | |
| X | No accessories | <input type="checkbox"/> |
| N | Gauge block 1/4" NPT (2 gauges included) | <input type="checkbox"/> |
| N = Special Options | | |
| N | No special options | <input type="checkbox"/> |
| T | 270 deg rotary version (no shaft spring) | <input type="checkbox"/> |

| | | | | | | | | | | | | | | | | | | | | |
|---|---|---|---|---|---|---|---|---|---|---|---|---|---|---|---|---|---|---|---|---|
| A | A | A | B | C | D | E | - | F | G | G | H | H | H | - | I | J | K | L | M | N |
|---|---|---|---|---|---|---|---|---|---|---|---|---|---|---|---|---|---|---|---|---|

* When J = P & F, only switches will be included, no 4-20 mA transmitter.
 * When G = RM, this option is not selectable. Switches can be installed as position sensing unit.

Note: For latest version of valid model code please see www.pmv.nu

9. Installation

Removal of cover

General purpose / Intrinsically safe

Remove cover by first loosening the screw (1) and then the two screws (2).

To install cover, first tighten the screw (1), then the two screws (2).

Tighten to 1.5 Nm ± 15%.



Air Preparation

Supply air should meet requirements specified on page 5. In order to have best performance and durability we recommend to install a combined filter/regulator in front of the supply air connection. Connect the air supply to the filter, which is connected to the D20 positioner.

tubing

It is recommended to use tubes with a minimum inner diameter of Ø 6 mm (¼”).

Gauge block

Gauge blocks are available for D20 series with ¼” NPT air connections. To install, ensure seals are aligned, then use 3 Nm (2.2 lb ft) of torque when fastening the gauge block to the positioner using the two screws supplied with the kit.

Gauge ports are available for D20 series with 1/8” NPT

Air supply requirements

Note: Poor quality air supply is the main cause of problems in pneumatic systems.

The air supply must be free from moisture, water, oil and particles and delivered @ 1.4-6 barg (20-85 psi)

Standard: DIN/ISO 8573-1-2001 3.2.3
 Filtered to 5 Micron, dew point -40°C/F
 Oil 1mg/m³ (0,83 ppm by weight)

The air must come from a refrigeration dried supply or be treated in such a way that its dew point is at least 10°C (18°F) below the lowest expected ambient temperature.

Before the air supply is connected to the positioner, we recommend the pipe/tube is opened freely for 2 to 3 minutes to allow any contamination to be blown out. Direct the air jet into a large paper bag to trap any water, oil, or other foreign materials. If this indicates that the air system is contaminated, it should be properly cleaned before continuing.



WARNING! Do not direct the open air jet towards people or objects because it may cause personal injury or damage.



9.1 Mounting

Note: If the positioner is installed in a hazardous environment, it must be of a type approved for this purpose.

All versions of the D20 positioner have an ISO F05 footprint **(A)**. The holes are used to attach the D20 to the mounting bracket **(B)**. Please contact PMV or your local distributor representative with actuator specifics for the proper mounting bracket and hardware.

The spindle shaft **S09 (C)** can be used to suit various actuators in question by the use of adapters.

It is important that the positioner's spindle shaft and the lever arms, that transfer the actuator movements, are correctly mounted. Any tension between these parts can cause incorrect operation and abnormal wear.

Spindle shafts

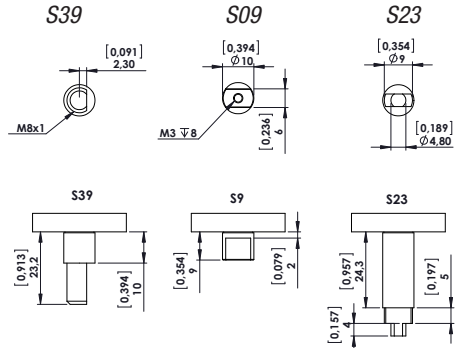

Note: There are many spindle options available depending on the actuator. Please contact your local PMV supplier for all options available.

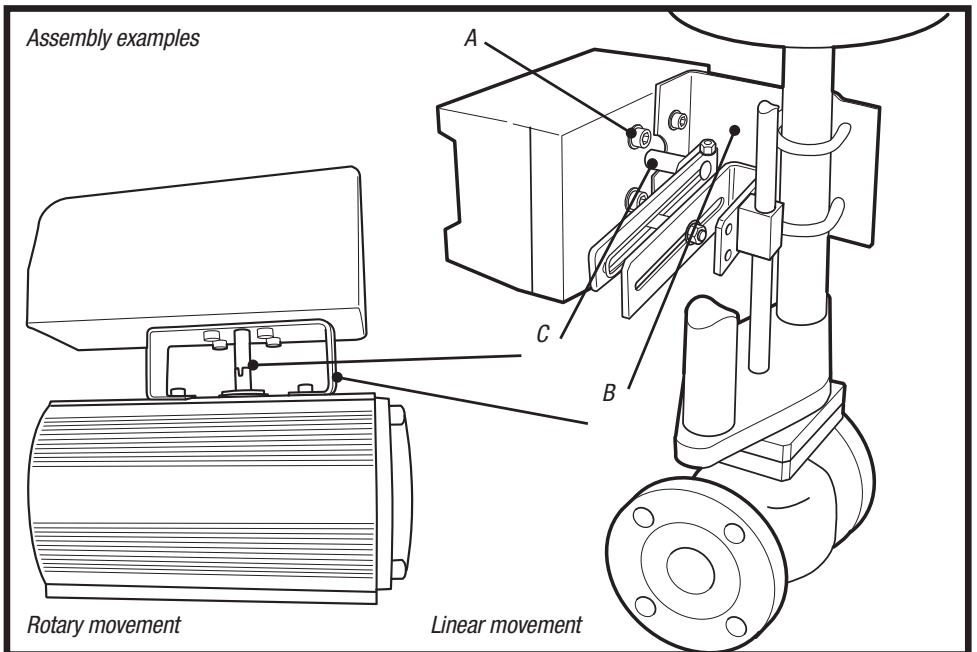

Adapter drawing
Suit shaft style "09"

S9 Adaptors

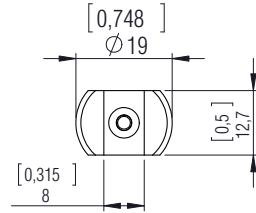
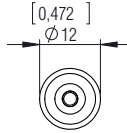
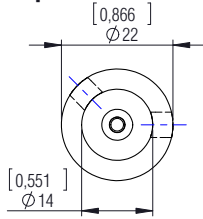

S1

S2

S6

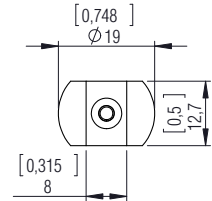
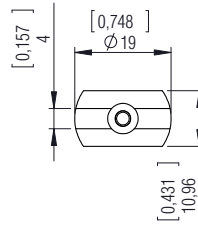
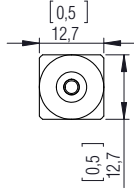
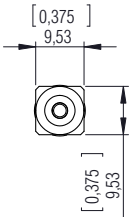
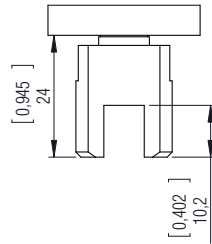
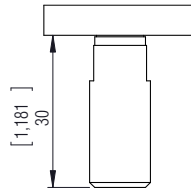
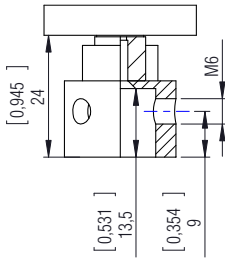

S26

S30

S36

S43

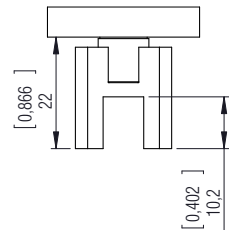
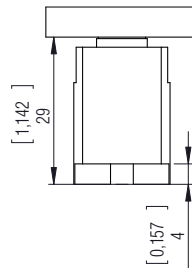
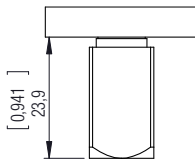
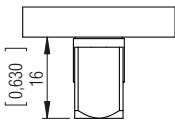

9.1.1 Linear pneumatic actuator

9.1.1.1 Mounting on a linear pneumatic actuator

The mounting of a rod actuator kit (according to NAMUR/IEC 534 part 6) is described in an example by using the following equipment:

Valve: Standard globe valve or equivalent

Actuator: Single-acting pneumatic actuator

Positioner: PMV D20 with mounting kit.

Pre-assembly: Valve with actuator (valve stroke is matched with the actuator stroke).

For mounting, proceed as follows:

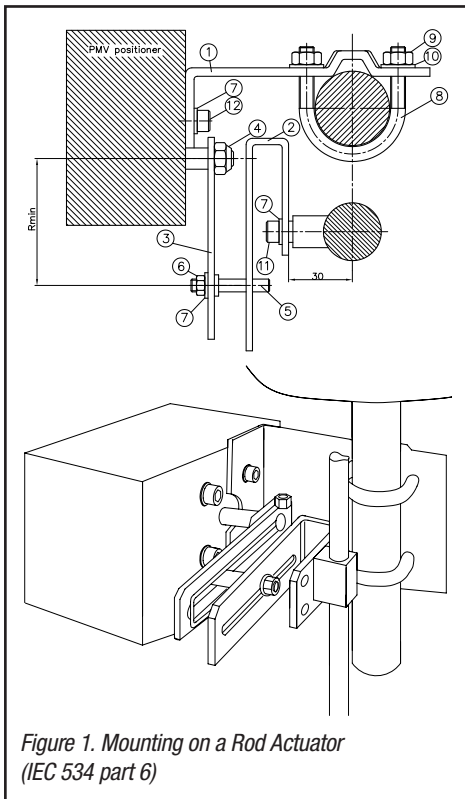



Figure 1. Mounting on a Rod Actuator (IEC 534 part 6)

Mounting the Follower Arm (figures 1 and 2)

1. Unscrew the lock nut for the follower arm attachment.
2. Place the follower arm on the shaft at the back of the positioner and fasten it with the lock nut. The follower pin should point back from the positioner.



CAUTION: Maximum torque
0,25 Nm (0,18 ft-lbs).

Mounting the stem clamp bracket and take-off arm (figure 1)

1. Attach the stem clamp bracket to the stem clamp and fasten it with two hexagon socket screws and lock washers.
2. Attach the take off arm to the stem clamp bracket and fasten it with a hexagon socket capscrew and a washer. Ensure the take-off arm slot is centered.

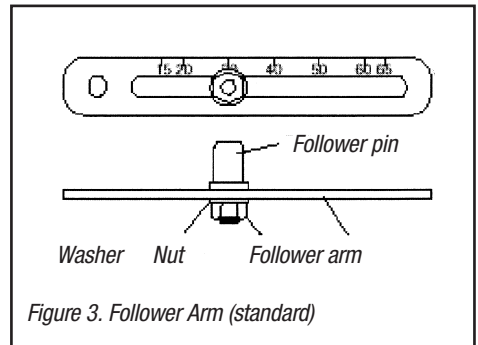

Figure 3. Follower Arm (standard)

Mounting the positioner (figure 1)

1. Adjust the actuator to mid-stroke.
2. Pre-assemble the mounting bracket on the left actuator leg hand-tight with two U-bolts, nuts and lockwashers.
3. Attach the positioner to the pre-assembled mounting bracket and fasten it with two hexagon head screws and two lock washers. Check that the follower pin is inserted in the slot of the take-off arm and the follower arm is positioned at a right angle to the outer edge of the positioner.
4. Tighten all screws and nuts.

Note: A slight unsymmetrical mounting increases the linearity deviation but does not affect the performance of the device. Depending on the actuator size and stroke it may be necessary to flip the take-off-arm (Figure 4) by 180° and attach it to the opposite side of the stem clamp bracket.

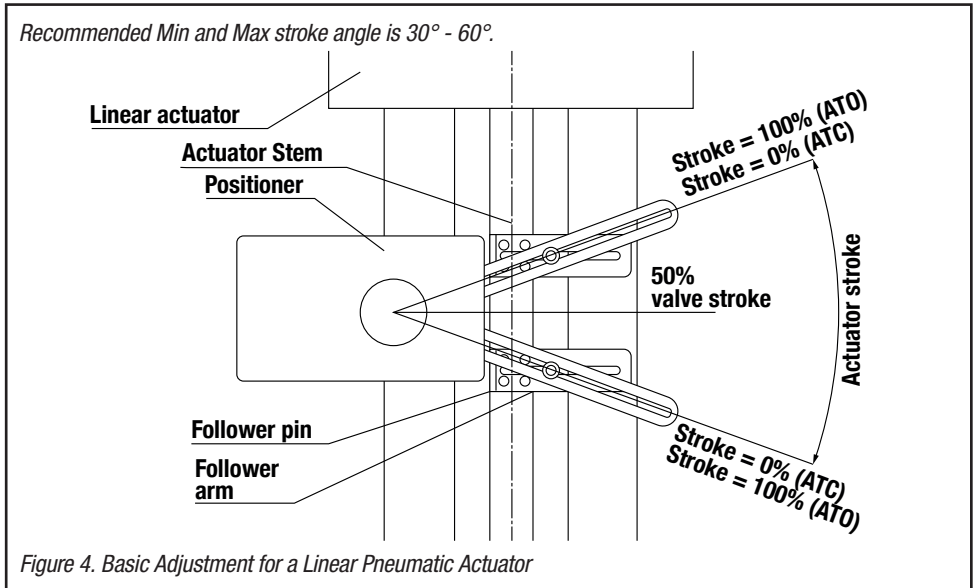
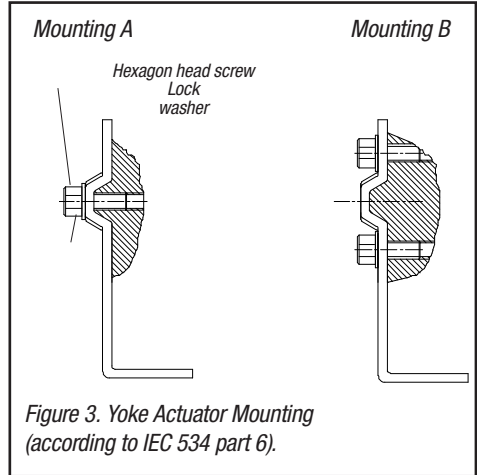

Figure 4. Basic Adjustment for a Linear Pneumatic Actuator

***Follower pin adjustment
(figure 4)***

The positioner follower pin must be adjusted to match the valve stroke in the following manner:

1. Adjust the follower pin (STROKE + 10 mm) as indicated on the follower arm’s embossed scale (Figure 2).
2. Exhaust the actuator.
3. Loosen the follower pin and shift it along the follower arm until the control marking on the feedback gear (Figure 3) is horizontal (points to the center of the feedback potentiometer). Fasten the follower pin in this position.
4. Adjust the actuator to full stroke and check the follower pin adjustment the same way as described in step 3. As the actuator strokes, the rotation of the feedback gear should be between the inner control markings. If the length of rotation is outside the control markings, adjust the follower pin farther out on the feedback lever to reduce the angle of rotation.

NOTE: Stroke the actuator carefully and ensure the follower arm does not interfere with valve parts, actuator or positioner. Do not adjust the follower pin too near to the slot end of the take-off arm.

The minimum lateral distance should be approximately 5 mm (0,2 inches) to prevent bending of the feed-back mechanism.

9.1.1.2 FlowTop direct mounting

Check O-ring **(8)**, Install bracket **(7)** to positioner and secure with 3x screws **(9)**

Check O-ring **(13)** or **(14)**, Install positioner to the actuator and secure with 2x screws **(10)**

Fit pin **(3)**, nut **(2)** and pin plate **(1)** on the valve stem and secure with 2x screws **(5)**

Fit lever arm **(6)** to positioner shaft.

No tubing needed, it's integrated with the actuator. Fit plug **(12)** in positioner out port.

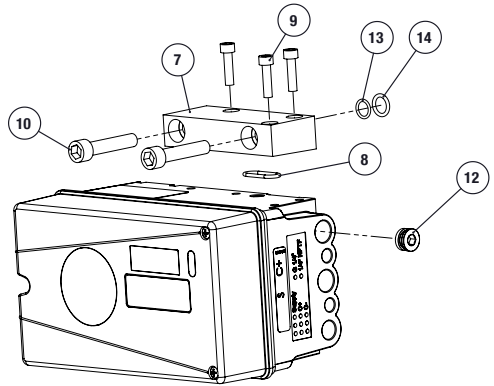
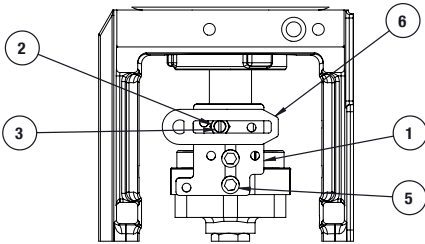
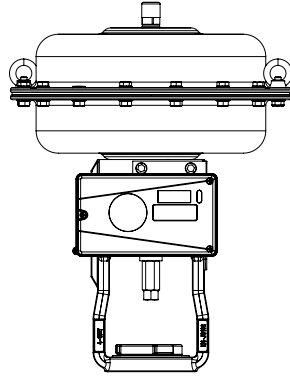

Pin plate and pin configuration for different actuators and stroke

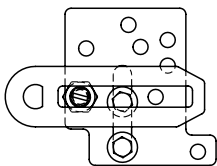

10 mm stroke 252

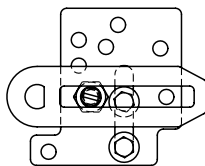

20 mm stroke 252

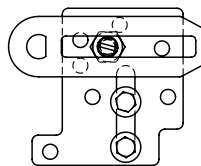

20 mm stroke 502

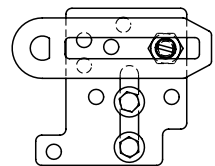

40 mm stroke 502

9.1.2 Rotary actuators

9.1.2.1 Mounting the positioner on a quarter-turn actuator (closed or open by spring)

The mounting of a pneumatic double-piston part-turn valve actuator (in accordance with VDI/VDE 3845) is described as an example by using the following equipment:

Quarter-turn valve actuator: Rack and pinion or cotch yoke, closed or open by spring.

9.1.2.2 VDI/VDE 3845 (NAMUR)

Mount bracket **(1)** to positioner. Secure with 4 x M6 screws **(2)** 2.5 nm (1.8 ft lbs)

Fit positioner on actuator and secure with 4 x screws **(3)**.

Install tubing **(4)** between actuator and positioner.

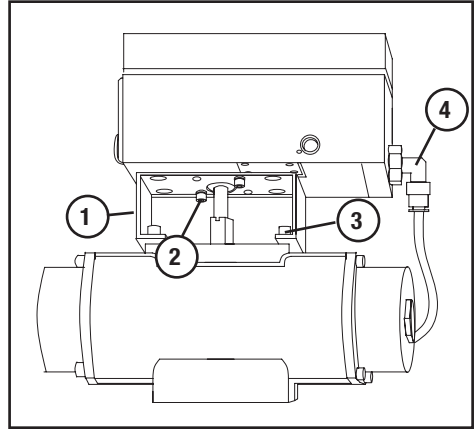

9.2 Air Connection

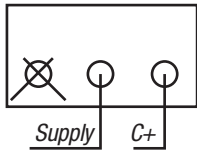

Single acting positioner, Direct function Actuator with closing spring

When the control signal increases, the pressure C+ to the actuator is *increased*. The valve stem moves upward and rotates the positioner spindle *counter-clockwise*. When the control signal drops to zero, C+ is vented and the valve closes.

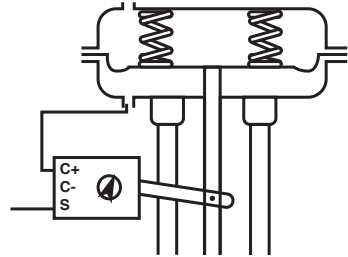

Reverse function Actuator with opening spring

When the control signal increases the pressure C+ to the actuator is *increased*. The valve stem moves downward and the positioner spindle rotates *clockwise*. When the control signal drops to zero, C+ is vented and the valve opens.

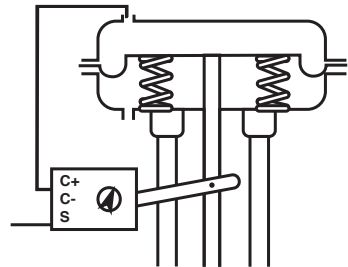

9.3 Electrical connections

Terminal block diagram for the D20-series.
The terminal block (right) for the positioner is accessible when the aluminum cover is removed.



Electrical Conduit connections and cable pathway:
1/2" NPT or M20 x 1,5

Remove the black plug with a coin or slotted head screwdriver

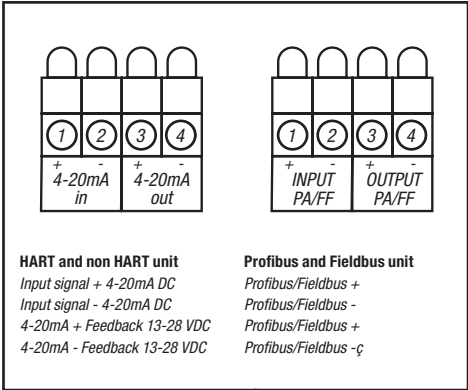

D20(D22) optional Switch or remote board

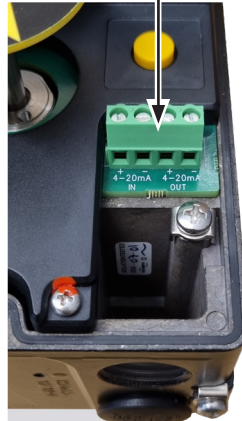
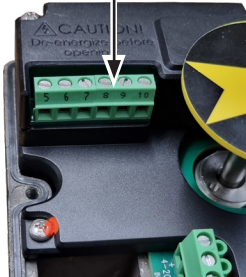
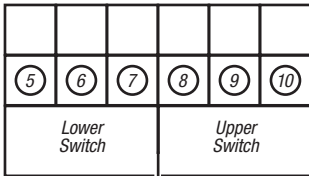

Warning! In a hazardous environment where there is a risk of explosion, electrical connections must comply with the relevant regulations.

| Switch option | | Terminal Block pin number | | | | | |
|---------------|-------------------------------------|---------------------------|-----|-----|-----|-----|-----|
| | | 5 | 6 | 7 | 8 | 9 | 10 |
| X | No feedback option | na. | na. | na. | na. | na. | na. |
| T | 4-20 mA transmitter, no switches | na. | na. | na. | na. | na. | na. |
| 5 | Slot type NAMUR sensor, P+F SJJ2-SN | - | + | na. | - | + | na. |
| 6 | Slot type NAMUR Sensor, P+F SJJ2-N | - | + | na. | - | + | na. |
| N | NAMUR V3 type sensor, P+F NJ2-V3-N | - | + | na. | - | + | na. |
| P | Limit switches Proximity SPDT | NO | NC | Com | NO | NC | Com |
| S | Limit switches Mechanical SPDT | NC | NO | Com | NC | NO | Com |

Mounting options

| | | | | | | | |
|----|---|-----|-----|-----|-----|----|----|
| RM | Remote Board (Feedback and switch option =x or T) | na. | na. | na. | CCW | RA | CW |
|----|---|-----|-----|-----|-----|----|----|

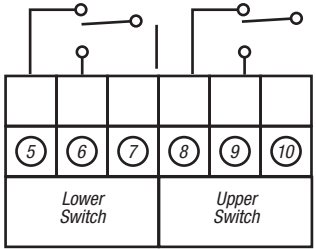

Connection of mechanical and proximity switches. (S,P)

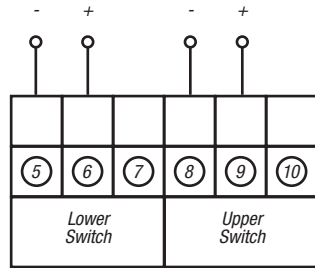

Connection of NAMUR switch. (N,5,6)

Remote Unit

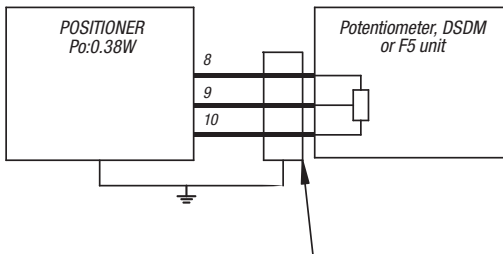

Requires shielded cable shorter than 10 m or 30 feet

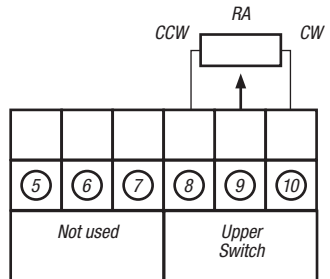

Connection of remote unit

Limit switch calibration

- Loosen screws **(1)** and adjust cams.
- Adjust lower cam first and then upper cam
- Tighten screws **(1)**

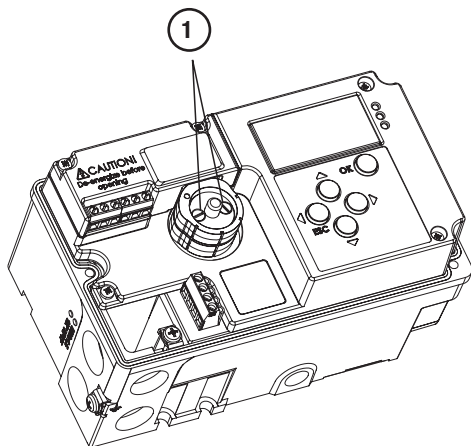

9.4 Wiring and grounding guidelines

Cable requirements: 24–16 AWG gauge wire sizes should be used for connection to the terminals. Wire sizes outside of this gauge range may not form a good connection or may cause damage to the terminals.

For installation practices and allowable cable lengths refer to the latest version of the HART Field Communications Protocol Application Guide, HART HCF LIT.

Input signal: 4 – 20 mA

Observe the minimum requirements of voltage and equivalent electrical load:

8 VDC at 20mA non HART version

9,4VDC at 20 mA HART version

The performance is ensured only for a minimum input current of 3,6mA.

| Connection | Description |
|------------|--|
| +1 | Input +4-20 mA |
| -2 | Input -4-20 mA |
| ↑ | Pneumatic output signal (outlet) Air supply |
| ○ | |
| ↓ | |
| ○ | |

Connect the 4-20 mA current source to terminals +1 and -2, see connection table.

The input loop current signal to the D20(D22) positioner is recommended to be in shielded cable. By tying shields to ground at only one end of the cable removes environmental and electrical noise. Connect the shield wire to the source. Shield wire should be insulated and ensure that is not connected to positioner side.

9.5 Grounding Screws

The grounding screws, located inside the positioner cover and near the electrical conduit connections, should be used to provide the unit with an adequate and reliable earth ground reference. Tie this ground to the same earth ground reference as the electrical metallic conduit. Additionally, the electrical metallic conduit should be earth grounded at both ends of its run.

Note: Any of the positioner ground screws must not be used to terminate signal shield wires. Shield wires should be terminated only at the signal source.

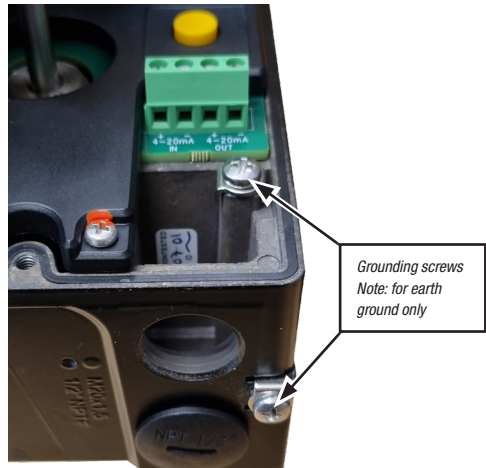

9.6 Electromagnetic compatibility

The PMV D20 digital positioner has been designed to operate correctly in electromagnetic (EM) fields found in typical industrial environments. Care should be taken to prevent the positioner from being used in environments with excessively high EM field strengths (greater than 10 V/m). Portable EM devices such as hand-held two-way radios should not be used within 30 cm of the device.

Ensure proper wiring and shielding techniques of the control lines, and route control lines away

from electro-magnetic sources that may cause unwanted noise.

An electromagnetic line filter can be used to further eliminate noise.

In the event of a severe electrostatic discharge near the positioner, the device should be inspected to ensure correct operability. It may be necessary to recalibrate the PMV D20 positioner to restore operation.

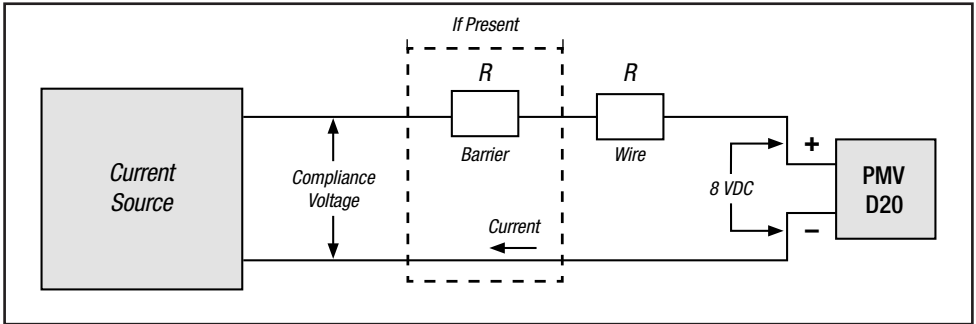

9.7 Compliance voltage

Output compliance voltage refers to the voltage limit the current source can provide. A current loop system consists of the current source, wiring resistance, barrier resistance (if present), and the PMV D20 impedance.

The PMV D20 requires that the current loop system allow for a 8.0 - 9.4 VDC drop across the positioner at maximum loop current.

$$\text{Voltage} = \text{Compliance Voltage}(\text{@Current}_{\text{MAX}})$$

$$- \text{Current}_{\text{MAX}}(R_{\text{barrier}} + R_{\text{wire}})$$

To support the PMV D20 the calculated voltage must be greater than 9.4 VDC for D20 HART and 8 VDC for non-HART.

Example: DCS Compliance Voltage = 19 V

$$R_{\text{barrier}} = 300\Omega$$

$$R_{\text{wire}} = 25\Omega$$

$$\text{CURRENT}_{\text{MAX}} = 20 \text{ mA}$$

$$\text{Voltage} = 19 \text{ V} - 0.020 \text{ A}(300\Omega + 25\Omega) = 12.5 \text{ V}$$

This system will support the PMV D20, as the voltage 12.5 V is greater than the required 8 VDC for non-HART and 9.4 VDC for HART.

CAUTION: Never connect a voltage source directly across the positioner terminals. This could cause permanent circuit board damage.

In order to determine if the loop will support the PMV D20, perform the following calculation:



10. Control

10.1 D20 Single push button

10.1.1 Calibration

- A. Apply 4 mA current as input signal.
- B. Wait for the Yellow LED to flash and then press the button for 5 sec. (Release the button when the three LEDs start to flash alternately).
- C. The calibration process starts and will take between 30 seconds to some minutes depending on the actuator size. The actuator goes to maximum, minimum positions and calculates the control parameters. The three LEDs will flash alternately during the calibration process.
- D. When calibration is completed, the 3 LEDs will rapidly flash alternately for a moment.

A successful calibration is indicated by yellow or green LED:

- G**
 Green LED flashes = In service
- Y**
 Yellow LED flashes = In service. The unit vents in max or min position.

An unsuccessfull calibration is indicated by error codes:

- R**
 D20 does not reach the setpoint.

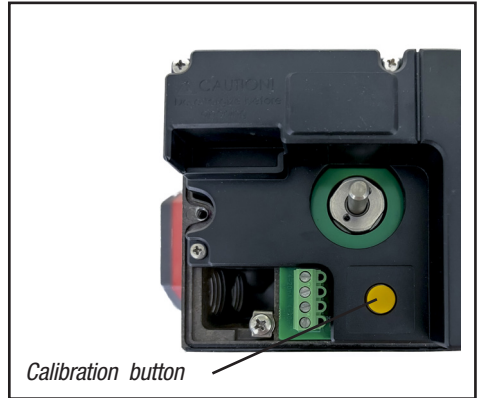

NOTE: For best performance, wait at least 10 min for the unit to do self calibration and learning process.

10.1.2 Set of Direct or Reverse action

Note: For safety reason, this operation has to be done max 5 minutes after calibration. If time has run out, or if power is disconnected during the five minutes, perform a new cali-bration, before changing the direction.

Run 4 mA. If valve is in right position, then check the position over the whole range (8, 12, 16 and 20 mA).



x3

If the direction need to be changed: press the button 3 times and the direction will change.

Check operation at 4 – 8 – 12 – 16 and 20 mA

10.1.3 Show gain setting

If the actuator position is unstable or selfoscillating after calibration, the gain can be adjusted.

Gain can be set from **A** (lowest) to **G** (highest). Default is **D**.



x4

To **show** the current gain setting, press the button four times.

To indicate the current setting, the LEDs flashes according to the following:

| | | |
|------------|--|------------------|
| LEDs show: | | G (Highest) |
| LEDs show: | | F |
| LEDs show: | | E |
| LEDs show: | | D Default |
| LEDs show: | | C |
| LEDs show: | | B |
| LEDs show: | | A (Lowest) |

The gain code sequence is repeated 5 times.

Button functions:

- Press 5 sec = Calibration
- Press x3 = Direct/reverse action
- Press x4 = Show gain setting
- Press x5 - x11 = Change gain setting

To indicate that a command is accepted, the three LED:s light up.



10.1.4 Change of gain setting

To lower the gain, press the button: 7, 6 or 5 times (5= lowest).

To increase the gain (if actuator is moving to slow).

Press the button: 9, 10 or 11 times (11= highest) to increase the gain.

The LED:s flashes alternately when the button is pressed. After gain change the LED:s show the gain code five times.

The default value after first calibration is D .

After this, the gain settings are finished.

| | | | |
|---|-----|-------------|----------------|
| ● | x11 | G (Highest) | |
| ● | x10 | F | ↑↑ |
| ● | x9 | E | |
| ● | x8 | D Default | Lower Higher |
| ● | x7 | C | |
| ● | x6 | B | ↓↓ |
| ● | x5 | A (Lowest) | |

10.1.5 Factory Reset and Full Calibration

Factory reset

- A. Press and hold button while switching on power (4-20 mA input) to the D20, keep the button pressed for 6 sec. The EEPROM will now be erased. Release the button when all three LEDs light up for a moment.
- B. Wait for the LEDs to start flashing yellow – red alternately. D20 is now in FACTORY MODE.

To calibrate 4-20 mA input signal

- C. Apply 4.0 mA input signal and then press the button three **(3)** times until the 3 LEDs will rapidly flash alternately for a moment and then LEDs will flash yellow – red again.
- D. Apply 20.0 mA input signal and then press the button three **(3)** times until the 3 LEDs will rapidly flash alternately for a moment and then the LEDs will flash yellow – green.

To calibrate 4-20 mA output signal

- E. The feedback transmitter output signal on pins 3 and 4 will now follow the input signal instead of the position. Apply 20.0 mA input signal, measure the output signal and adjust the input signal up/ down until the output signal is 20.0 mA. Then press the button three **(3)** times until the 3 LEDs will rapidly flash alternately for a moment and LEDs will flash yellow – green again.
- F. The output signal on pins 3 and 4 will continue to follow the input signal instead of the position. Apply 4.0 mA input signal, measure the output signal and adjust the input signal up/ down until the output signal is 4.0 mA. Then press the button three **(3)** times until the 3 LEDs will rapidly flash alternately for a moment and yellow LED will flash.
- G. The D20 is now ready for calibration.

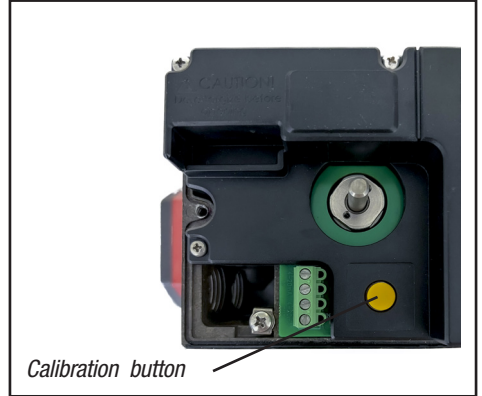

Refer to [page 25](#) for the D20 calibration process.

Notes!

The whole processes specified on this page should be completed for the D20 to function properly.

For best performance, wait at least 10 min for the unit to do self calibration and learning process.

10.2 D22 5 Push buttons

10.2.1 Menus and 5 Pushbuttons

The positioner is controlled using the five push buttons and the display, which are accessible when the aluminum cover is removed.

For normal functioning, the display shows the current value. Press the ESC button for two seconds to display the main menu.

Use the push buttons  to browse through the main menu and the sub-menus.

The main menu is divided up into a basic menu and a full menu.

10.2.2 Other functions

ESC

Exit the menu without making any changes (as long as any changes have not been confirmed with OK).

FUNC

To select function and change parameters.

OK

To confirm selection or change of parameters.

MENU INDICATOR

Displays the position of the current menu row in the menu.

IN SERVICE

The positioner is following the input signal. This is the normal status when the positioner is working.

OUT OF SERVICE

The positioner is not following the input signal. Critical parameters can be changed.

MANUAL

The positioner can be stroked manually using the push buttons. See section “Man/Auto”, [page 39](#).

OUT OF SERVICE
MANUAL



UNPROTECTED OK

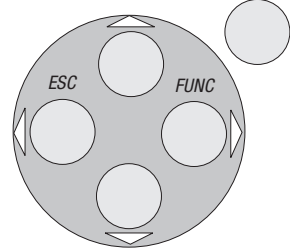

UNPROTECTED

Most of the parameters can be changed when the positioner is in the “Unprotected” position. However, critical parameters are locked when the positioner is in the “In service” position.

LED color (R=Red, Y=Yellow, G=Green)

| Codes during In Service | | |
|-------------------------|---|--|
| | R | Actual valve position deviates from requested/set position |
| | Y | Fully opened/closed valve using Cut Off (= OK) |
| | G | Controlling valve position (= OK) |

| Codes during Out of service | | | |
|-----------------------------|---|---|--------------------------------|
| | R | Y | Input signal not calibrated |
| | Y | G | Feedback signal not calibrated |
| | Y | Y | Out of Service (= OK) |

| Calibration alarm | | | |
|-------------------|---|---|---|
| | R | G | No feedback movement. Check linkage from actuator to positioner |
| | R | Y | No air available. *(alarm available only when pressure sensors installed) |
| R | G | G | No pot connection. Check pot cable inside positioner. |
| R | Y | Y | No air relay. Check cable inside positioner. |
| R | Y | G | Pot not calibrated. Go to Calibrate->Expert->Pot on LCD menu. |

10.2.3 Menu indicator

There are indicators at both sides of the display window and they indicate as follows:

Flashing in position *Out of service*

Flashing in position *Manual*

Displayed in position *Unprotected*

The indicators on the right-hand side show the position in the current menu.



10.2.4 Menus

To display the menus you can select:

- *Basic menu*, which means you can browse through four different menu items

- *Full menu*, which comprises ten steps. Use the Shift Menu to browse through the menu items

Full Menu can be locked out using a passcode.

The main menus are shown on the next page and the sub-menus on the subsequent pages.

10.2.5 Changing parameter values

Change by pressing ◀ ▶ until the desired figure is flashing.

Press ◀ ▶ to step to the desired figure. Confirm by pressing OK.

A change can be undone by pressing the *ESC* button, which returns you to the previous menu.

10.2.6 Menu System

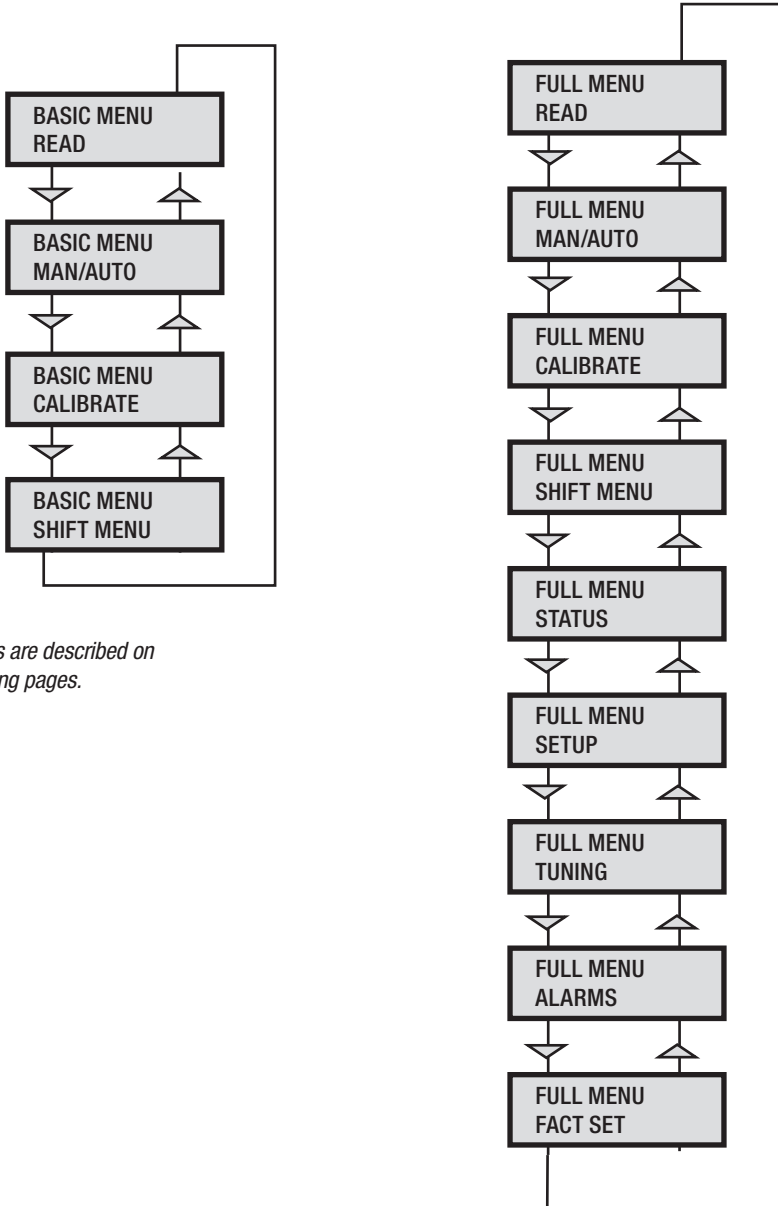

The menus are described on the following pages.

**BASIC MENU
CALIBRATE** →

First start

“Calibrate” is displayed in the basic menu automatically, the first time power is applied. It can be selected from the basic or full menu at any time.

Tip! Instant quick calibration

The D22 can be instantly calibrated by pressing the top + bottom buttons for 5 seconds (see picture). This function is available from any menu position.

A complete auto-calibration will take a few minutes depending on size of actuator and includes end limit calibration (zero and span), auto-tuning (dynamically sets the control parameters for the actuated package the positioner is controlling) and a check of the movement speed. Start the automatic calibration by selecting *Auto-Cal* and then answer the questions in the display by pressing *OK* or the respective arrow.

Calibration error messages

If a fault occurs during calibration, one of the following error messages can be displayed:

No movement/press ESC to abort

Typically the result of an air delivery issue to the actuator, a stuck valve or actuator, or incorrect mounting and/or linkage arrangement. Check for proper supply air to the positioner, pinched tubing, proper actuator sizing, proper linkage and mounting arrangement.

Pot uncalibrated/press ESC to abort

The potentiometer is out of range. The potentiometer is aligned using the Calibrate - Expert cal - pot Menu. The calibration sequence must be restarted after the fault is corrected.



Instant quick calibration

First start, Profibus PA

For Profibus PA, connect the input signal at pos 1 and 2 on the terminal block. See Electrical connections in the manual.

In the SETUP/Devicedata/Profibus: change the address from 126 to any number between 1-125. Never use the same number with more than one unit. Install values in failsafe mode, for communication when loss of signal. Calibrate the unit.

GSD files are available at our web-page www.pmv.nu

To install the D20_PROFIBUS.DDL file to Siemens SIMATIC PDM.

1. Move the files to the directory where the DeviceInstall.exe is located.
2. Run DeviceInstall.exe

| Parameter | Description | | BYTE |
|-----------|------------------|--|-------|
| SP | Setpoint | The SP has 5 bytes, 4 bytes for the float value and one status byte. The status byte needs to be 128 (0x80Hex) or higher for the D20 to accept it. | 4+1=5 |
| READBACK | Position | The READBACK has 5 bytes, 4 bytes for the float value and one status byte. | 4+1=5 |
| POS_D | Digital position | Returns actual position as a digital value with definitions as below 0 = Not initialized 1 = Closed 2 = Opened 3 = Intermediate | 2 |
| CHECKBACK | | Detailed information of the device, coded bit wise. Several messages can occur at the same time. | 3 |
| RCAS_IN | Remote Cascade | The RCAS_IN has 5 bytes, 4 bytes for the float value and one status byte. | 4+1=5 |
| RCAS_OUT | Remote Cascade | The RCAS_OUT has 5 bytes, 4 bytes for the float value and one status byte. | 4+1=5 |

Status Byte Table

| MSB | LSB | | Meaning | D20 info | | | | | |
|-----|-----|---|---------|----------|---|---|---|---------------------|--|
| 0 | 0 | 0 | 0 | 1 | 0 | x | x | Not connected | |
| 0 | 0 | 0 | 0 | 1 | 1 | x | x | Device failure | PROFIBUS PA module failure |
| 0 | 0 | 0 | 1 | 0 | 0 | x | x | Sensor failure | No sensor value |
| 0 | 0 | 0 | 1 | 1 | 1 | x | x | Out of service | AI Function Block in O/S mode |
| 1 | 0 | 0 | 0 | 0 | 0 | x | x | Good - Non cascade | Measured value OK All Alarm values used |
| 1 | 0 | 0 | 0 | 0 | 0 | 0 | 0 | OK | |
| 1 | 0 | 0 | 0 | 1 | 0 | 0 | 1 | Below low limit Lo | Advisory alarm |
| 1 | 0 | 0 | 0 | 1 | 0 | 1 | 1 | Above high limit Hi | Advisory alarm |
| 1 | 0 | 0 | 0 | 1 | 1 | 0 | 1 | Lo-Lo | Critical alarm |
| 1 | 0 | 0 | 0 | 1 | 1 | 1 | 1 | Hi-Hi | Critical alarm |

Example SP = 43.7% and 50%

| Float | Hex | Status |
|-------|-------------|--------|
| 43.7 | 42 2E CC CD | 80 |
| 50.0 | 42 48 00 00 | 80 |

(FF) Foundation Fieldbus function blocks

Function blocks are sets of data sorted by function and use. They can be connected to each other to solve a control process, or to a controlling DCS. To get a good introduction and understanding of FF look at www.fieldbus.org and download the “Technical Overview” from the About FF pages.

(TB) Transducer Block

The TB contains unit specific data. Most of the parameters are the same as parameters found on the display. The data and the order of data varies between different products. The AO-block setpoint (SP) and process value (PV) parameters are transceived to the TB through a channel. The TB has to be in AUTO for the AO-block to be in AUTO.

The positioner has to be in menu-auto mode and in service to be controlled from the Fieldbus. If the positioner is placed in menu-manual mode then the transducer block will be forced to (LO) local override. In this way a person in the field will be able to control the positioner from the keypad, without collision with a control loop.

(RB) Resource Block

The RB is a set of parameters that looks the same for all units and products. The values of the RB define unit information that concerns the Fieldbus Protocol such as MANUFAC_ID which informs the unique manufacturer id. For Flowserve it is 0x464C53. The RB has to be in AUTO for the AO-block to be in AUTO.

(AO) Analogue Output Block

The AO follows Fieldbus Foundation’s standard on content and action. It is used for transferring (SP) setpoints from the bus to the positioner.

CAS_IN (cascade input) and RCAS_IN (remote cascade input) are selected as inputs to the AO block depending on the MODE_BLK parameter. The selected input will be relayed to the SP parameter of the AO block. BKCAL_OUT (back calculated output) is a calculated output that can be sent back to a controlling object so that

AO-block overview

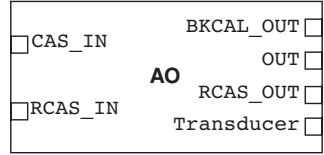

control bumps can be avoided. Usually the BKCAL_OUT is set to be the (PV) process value of the AO-block, i.e. the actual measured position of the valve. OUT is the primary calculated output of the AO block. During a limited action (ramping) of the AO block the RCAS_OUT parameter will supply the final setpoint and the OUT parameter will be the limited output. The transducer block is connected through a channel to the AO block. Through this channel the OUT value and SP are transceived.

In order to set the AO block to AUTO, the TB and the RB have to be in AUTO. Further the AO block has to be scheduled. Using National Instruments Configurator; scheduling can be done by adding the unit to a project and then click on the “upload to device” icon.

To write a setpoint value by hand, add Man to MODE->Permitted parameter, and then choose MODE->Target to Man. Make sure that the unit is scheduled.

Example

A typical FF block loop control might look like the following: Where the positioner is represented by the AO-block.

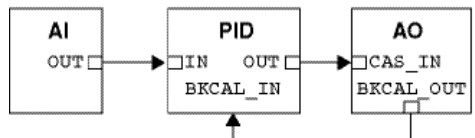



The contents of the menu are shown on the next page. The various menu texts are described below.

Auto-Cal

Auto-tuning and calibration of end positions

Start tune

Starts the tuning. Questions/commands are displayed during calibration. Select the type of movement, function, etc. with  and confirm with OK as shown in the chart on the next page.

Lose prev value? OK?

A warning that the value set previously will be lost (not during the first auto-tuning).

Direction? Air-to-open.

Select for direct function.

Direction? Air-to-close.

Select for reverse function.

In service? Press OK

Calibration finished. Press OK to start positioner functioning. (If ESC is pressed, the positioner assumes the "Out of service" position but the calibration is retained).

TravelCal

Calibration of end positions

Start cal

Start end position calibration.

Lose prev value? OK?

A warning that the previously set value will be lost. Confirm with OK. The calibration sequence starts.

In service? Press OK

Calibration finished. Press OK to start positioner functioning. (If ESC is pressed, the positioner assumes the "Out of service" position but the calibration is retained).

Perform

Setting gain

Normal

100% gain

Perform G, F, E, D, C, B, A

Possibility to select a lower gain in steps. Default setting is D.

Note: Original P. I. D. will always be shown in display

Feedback option
Calibration of the 4-20 mA transmitter

Go to menu shown in diagram.
 Connect mA meter I and check reading.
 Adjust output signal using Up or Down key
 until meter I reads 4.00 mA.
 Finish by pressing OK.
 Repeat the above for 20 mA.

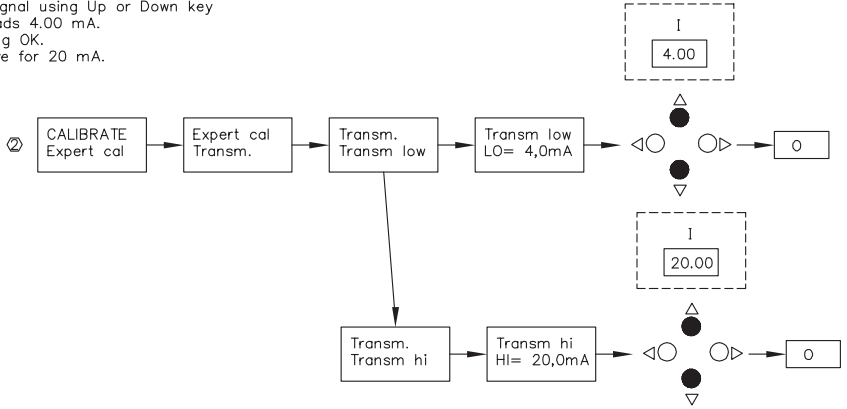

Expert Calibration

When entering "ExpertCal" mode - walk through the list of parameters described below.

Set values where applicable. Confirm by pressing OK.

Set point LO: Use the calibrator set to 4 mA (or set another value on the display). Press OK.

Set point HI: Use a calibrator of 20 mA (or set another value on the display). Press OK.

Pressure LO: Use a supply of 1.4 bar (20 psi) (or set another value on the display). Press OK. Pressure read out only possible on D20 with built in pressure sensor.

Pressure HI: Use a supply of 8 bar (115 psi) (or set another value on the display). Press OK. Pressure read out only possible on D20 with built in pressure sensor.

Transmitter: Connect 10 - 28 VDC. Connect an external mA meter to the loop. Read low value on mA meter and adjust with up/down key. Press OK to set low value. Repeat procedure to set High value.

Also see video on www.pmv.nu

Pot: Potentiometer setting, see section 5.

Also see video on www.pmv.nu

Full reset: Resets all set values and enters Factory mode. To reset the values only, use FACT SET in main menu, see below.

The menu contents are shown in the figures on the right and the texts are described below:



Current values can be read using the Read Menu and some values can be reset.

- Pos* Shows current position
- Set&pos* Set point and position
- Set&dev* Set point and deviation
- Pos graph* Shows position graph
- Temp* Shows current temperature

Statistics

- n cycles* Shows number of cycles. 1 cycle = [move of valve +change direction+move opposite direction] regardless of size of each move/stroke.
- Acc travel* Travel = [accumulated % valve has moved/100].
Example: move 60% up + move 40% down =>Acc travel = 1
- mean dev* Shows accumulated deviation in %
- m.abs dev* Shows accumulated absolute deviation in %
- # of resets* Shows number of resets
- runtime* Shows accumulated runtime since last reset
- Extr temp* Shows extreme min and max temperature
- Histogram* Shows position and time for position value
- Alarms* Displays tripped alarms

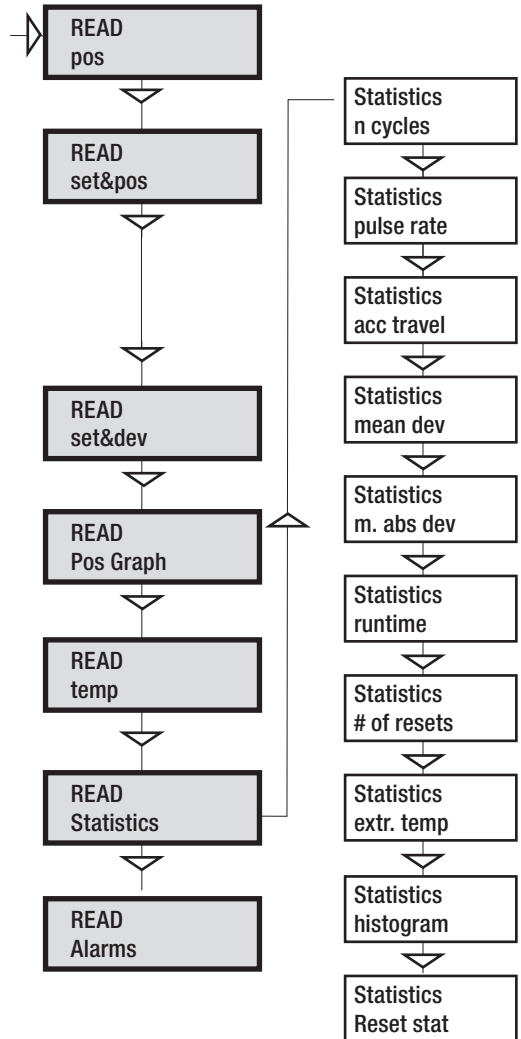



The Man/Auto menu is used to change between manual and automatic modes.

The menu contents are shown in the figures on the right and the various texts are described below:

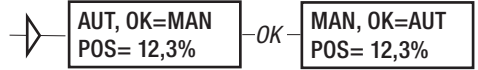

AUT, OK = MAN

Positioner in automatic mode

MAN, OK = AUT

Positioner in manual mode

Note: When changing between *MAN* and *AUT* mode, the *OK* button must be pressed for 3 seconds.

In the *MAN* mode, the value of POS can be changed using . The push-buttons increase/decrease the value in steps. The value can also be changed in the same way as for the other parameter values, as described on [page 30](#).

Other functions

C+ can be fully opened by pressing and then immediately *OK* simultaneously.

C- can be fully opened by pressing and *OK* simultaneously.

C+ and C- can be fully opened for blowing clean by pressing and *OK* simultaneously.



The Shift Menu is used to choose between the basic menu and the full menu.

The menu contents are shown in the figures on the right and the various texts are described below:

- No Full menu selected.
- Yes Basic menu selected.

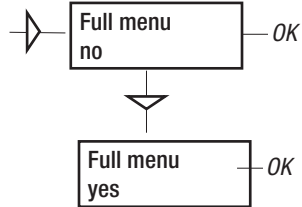

Note: The Menu can be locked with a passcode, see Setup menu.



The Status Menu is used to select whether or not the positioner is in service.

The menu contents are shown in the figures on the right and the various texts are described below:

- o o service* Not in service. Flashing indicator in upper left-hand corner of display.
- in service* Positioner in service. Critical parameters cannot be changed.

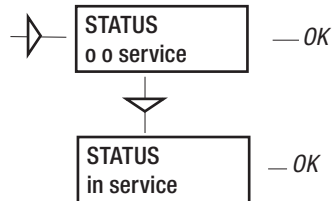

Note: When changing between *In service* and *Out of service*, the *OK* button must be pressed for 3 seconds.



The Setup Menu is used for various settings.

The menu contents are shown in the chart on the next page and the various texts are described below:

| Actuator | Type of actuator | Size of actuator | Time out |
|-----------------|-------------------------|-------------------------|-----------------|
| Rotating | Rotating actuator. | Small | 10 s |
| Linear | Linear actuator. | Medium | 25 s |
| | | Large | 60 s |
| | | Extra large | 180 s |

Lever *Only for linear actuator.*
 Lever stroke Stroke length to achieve correct display. Input only needed in case display value is off
 Level cal Calibration of positions to achieve correct display.

Direction
 Direct Direct function (signal increase opens). Indicator/spindle rotates counter-clock wise.
 Reverse Reverse function.

Character *Curves that show position as a function of input signal.*

Linear }
 Equal % } See diagram.
 Quick open }
 Sqr root }

Custom Create own curve.

Cust chr
 # of point Specify number of points (3, 5, 9, 17, or 33)
 Cust curve Enter values on X and Y axes.

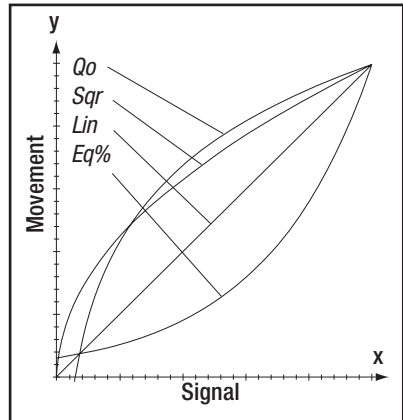

Curr range (Use this function to split range)

0%=4.0 mA
 100%=20.0 mA

Possibility of selecting which input signal values will correspond to 0% and 100% movement respectively.

Examples of settings: 4 mA = 0%, 12 mA = 100%, 12 mA = 0%, 20 mA = 100%.

| | |
|-------------------|---|
| Trvl range | Setting end positions |
| 0%=0.0% | Select Out of Service. Set percentage value for desired end position (e.g. 3%). |
| Set 0% | Select In Service. Connect calibrator. Move forward to desired end position (0%) and press OK. |
| 100%=100.0% | Select Out of Service. Set percentage value for desired end position (e.g. 97%). |
| Set 100% | Select In Service. Connect calibrator. Move forward to desired end position (100%) and press OK. |
| Trvl ctrl | Behavior at set end position |
| Set low | Choose between Free (positioner will control until a mechanical top is reached), Limit (stop at set end position), and Cut off (Default value. Go directly to a mechanical stop at a redefined setpoint). |
| Set high | Similar to Set low. |
| Values | Select position for Cut off and Limit at the respective end positions. |

Passcode **Setting passcode for access to the menu**
 Numbers between 0000 and 9999 can be used as passcodes. 0 = no passcode required.

| | |
|-------------------|--|
| Appearance | On display |
| Language | Select menu language. |
| Units | Select units. |
| Def. Display | Select value(s) to be displayed during service. The display reverts to this value 10 minutes after any change is made. |

| | |
|------------|---|
| Start menu | Start in Basic menu or Full menu. |
| Orient | Orientation of text on display. |
| Par mode | Display of control parameters such as P, I, D or K, Ti, Td. |

Devicedata
 HW rew }
 SW rew } General parameters.
 Capability }

HART Menu with HART parameters. Only amendable with HART communicator. It is possible to read from display.

Profibus PA

| | |
|------------|--|
| Status | Indicates present status |
| Device ID | Serial number |
| Address | 1-126 |
| Tag | Allotted ID |
| Descriptor | ID description |
| Date | SW release date |
| Failsafe | Value = preset pos Time = Set time +10sec= time before movement Valve act = failsafe (preset pos) or last value (present pos) Alarm out= On/Off |

Foundation Fieldbus

| | |
|-------------|---|
| Device ID | Serial number |
| Nod address | Address on the bus provided by the DCS system |
| TAG–PD_TAG | Name provided by the DCS system |
| Descriptor | D20 positioner |
| Date | SW release date |
| Sim jumper | Simulate jumper, FF simulation functionality activated = ON |



The menu contents are shown in the chart on the next page and the various texts are described below:

Close time Minimum time from fully open to closed.

Open time Minimum time from closed to fully open.

Deadband Setting deadband. Min. 0.1%.

Expert Advanced settings.

Control See explanations below.

Togglestep Test tool for checking functions. Overlays a square wave on the set value.

Self test Internal test of processor

Undo You can read last 20 changes.

P,I,D and K,Ti,Td parameters

If one of the gains is changed, the corresponding value in the other gain set is changed accordingly.

FULL MENU
ALARMS

The menu contents are shown in the chart on the next page and the various texts are described below:

| | | |
|-------------------|--|--------------------|
| <i>Deviation</i> | <i>Alarm generated when deviation occurs</i> | |
| <i>On/Off</i> | <i>Alarm on/off.</i> | |
| <i>Distance</i> | <i>Allowed distance before alarm is generated.</i> | |
| <i>Time</i> | <i>Total deviation time before alarm is generated.</i> | |
| <i>Alarm out</i> | <i>Select ON/OFF offers output on terminals.</i> | |
| <i>Valve act</i> | <i>Behavior of valve when alarm is generated.</i> | |
| | | |
| <i>Limit 1</i> | <i>Alarm above/below a certain level.</i> | |
| <i>On/Off</i> | <i>Alarm on/off.</i> | |
| <i>Minipos</i> | <i>Setting of desired min. position.</i> | } |
| <i>Maxpos</i> | <i>Setting of desired max. position.</i> | |
| <i>Hysteresis</i> | <i>Desired hysteresis.</i> | |
| <i>Alarm on</i> | <i>Select ON/OFF offers output on terminals.</i> | |
| <i>Valve act</i> | <i>Behavior of valve when alarm is generated.</i> | |
| | | See diagram below! |
| <i>Limit 2</i> | <i>See Limit 1.</i> | |

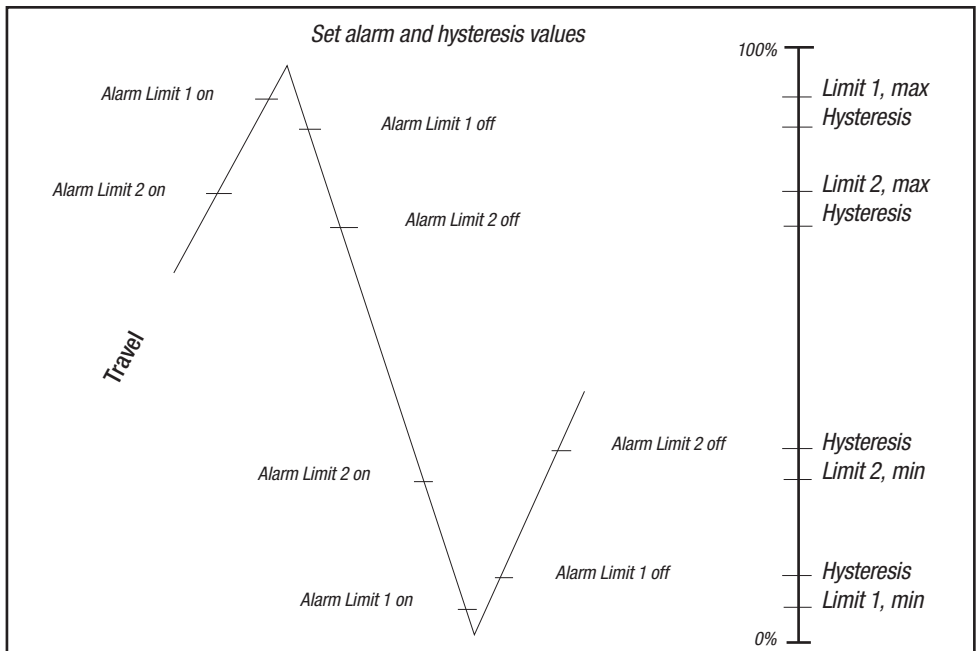

| | |
|-------------------|---|
| <i>Temp</i> | <i>Alarm based on temperature</i> |
| On/Off | Temperature alarm on/off. |
| Low temp | Temperature setting. |
| High temp | Temperature setting. |
| Hysteresis | Allowed hysteresis. |
| Alarm out | Select ON/OFF offers output on terminals. |
| Valve act | Behavior of valve when alarm is generated. |

| | |
|------------|---|
| Valve act | |
| No action | Alarm generated only. Operations not affected. |
| Goto open | Valve moves to 100%. Positioner changes to position Manual. |
| Goto close | Valve moves to 0%. Positioner changes to position Manual. |
| Manual | Valve stays in unchanged position. Positioner moves to position Manual. |



The menu contents are shown in the chart below.

The default values that were set on delivery can be reset using the Fact Set menu. Values from calibration and from other settings will then be lost.

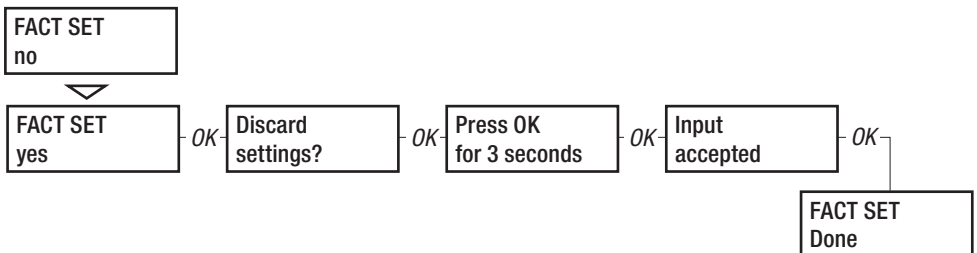

11. Maintenance/service

When carrying out service, replacing a circuit board, etc., it may be necessary to remove and refit various parts of the positioner. This is described on the following pages.

Read the Safety Instructions on [page 4](#) and [page 5](#) before starting work on the positioner.

Cleanliness is essential when working with the positioner. Contamination in the air ducts will inevitably lead to operational disturbances. Do not disassemble the unit more than that described here.

DO NOT disassemble the valve block apart because its function will be impaired.

When working with the D20 positioner, the work place must be equipped with ESD protection before the work is started.



Always turn off the air and electrical supplies before starting any work.



Please see section for special conditions for safe use and spare parts on [page 5!](#)

Please contact a Flowserve office for information regarding proper procedures. www.pmv.nu or infopmv@flowserve.com

11.1 Disassembling D20

Removing cover and inner cover

- Unscrew the screws **(A)** and remove the cover. When mounting cover – see [page 5](#). Torque the screws to 0,9 Nm.
- Pull off the arrow pointer, **(B)**.
- Unscrew the screws **(C)** and remove the inner cover. In reinstalling the inner cover, torque the screws to 0,4 Nm.
- If equipped with switches remove the cam stack

Note: Removing inner cover will void warranty.

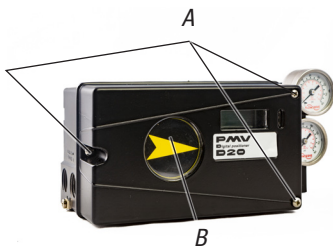

11.2 Circuit boards (PCB)



Warning! Disconnect or switch off the electric power supply before starting any work.

- Lift off the display PCB..
- Release the cable connections.
- Unscrew the two screws B and lift up the circuit board.
- In reinstalling the circuit board, torque the screws to 0,4 Nm.

B

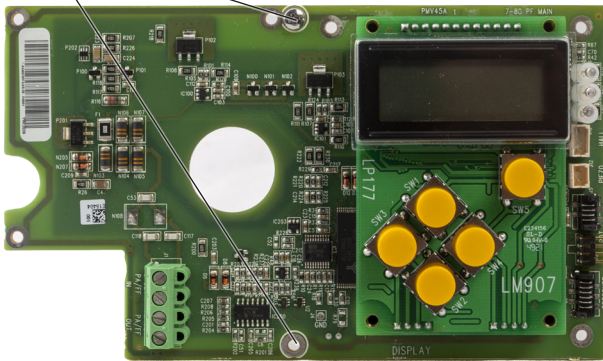

11.3 Limit Switches

Loosen two x screws holding the plastic cover and remove the screws. Pull out the plastic cover. Break away the plastic protection located on the main plastic cover to ensure there is an opening for the switches/cams. In reinstalling the plastic cover, torque the screws to 0,4 Nm.

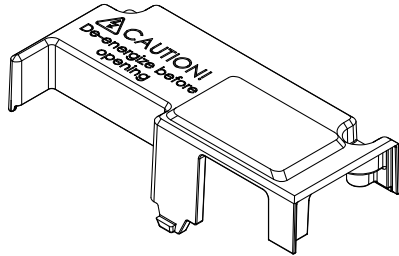

When installing the switch card, make sure it is placed correctly. Secure the PC Board with the two screws holding the plastic cover. Make sure the holes are centered before tightening the screws. Torque the screws to 0,4 Nm.

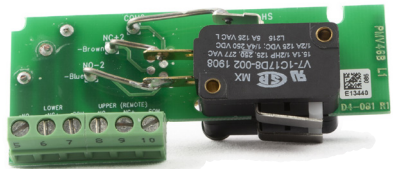

Note: When installing the cam assembly for mechanical switches, retract both switch arms first.

Install the cam assembly and tighten the screws loosely to obtain enough friction to lock the cams.

Adjust the lower cam first, then the upper cam. See [page 22](#).



11.4 Valve block



Warning! Turn off the air and electric power supply before starting any work.

- Remove the three screws **(A)** and lift out the valve block

Note: Do not disassemble the valve block

- When installing the valve block — torque the two screws to 0,4 Nm.

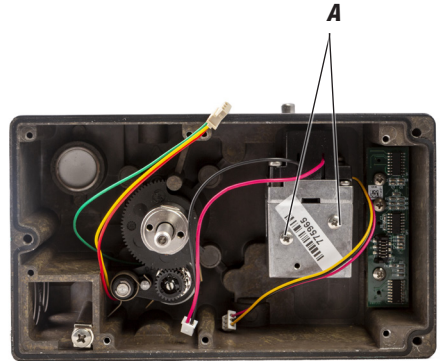

11.5 Potentiometer 90° (270°) spring loaded potentiometer

The spring-loaded potentiometer can be removed from the gearwheel for calibration or replacement.

If the potentiometer is replaced or the setting is changed, it must be calibrated.

- Select the menu Calibrate - Expert - Cal pot. The display shows Set gear.
- Turn the spindle shaft clockwise to end position and press OK. Either turn manually or use the up/down arrows (with supply air) to stroke the positioner to turn the shaft clockwise.
- Move spring **(1)** aside and disengage cogwheels. Turn potentiometer according to display until OK is shown. Press OK. See drawing below.
- Move back spring **(1)** and secure potentiometer **(2)** calibration. See drawing below. Spring **(1)** must allow a small play but not so big that the cogs can disengage.

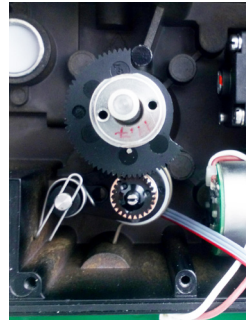
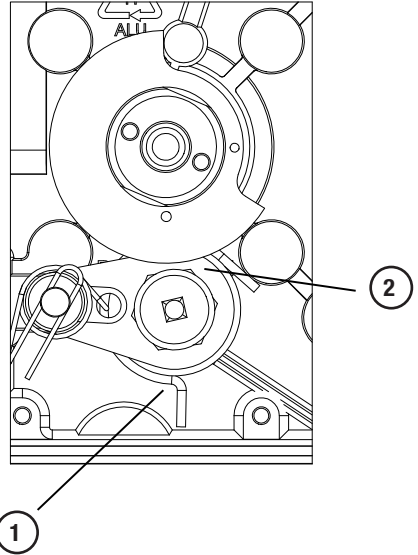

Potentiometer and cogwheel for 90° rotation

12. Troubleshooting

| Symptom | Action |
|---|--|
| Input signal change to positioner does not affect actuator position. | <ul style="list-style-type: none"> • Check air supply pressure, air cleanliness, and connection between positioner and actuator. • Out of service, in manual mode. • Check input signal to positioner. • Check mounting and connections of positioner and actuator. |
| Change in input signal to positioner makes actuator move to its end position. | <ul style="list-style-type: none"> • Check input signal. • Check mounting and connections of positioner and actuator. |
| Inaccurate control. | <ul style="list-style-type: none"> • Perform Auto-calibration and check for any leaks. • Try high and low gain settings. • Uneven air supply pressure. • Uneven input signal. • Wrong size of actuator being used. • High friction in actuator/valve package. • Excess play in actuator/valve package. • Excess play in mounting of positioner on actuator. • Dirty/humid supply air. |
| Slow movements, unstable regulation. | <ul style="list-style-type: none"> • Implement auto-tuning. • Increase the deadband (Tuning menu). • Adjust Performance (Calibrate menu). |

13. Technical data

| | |
|-------------------------|---|
| Rotation angle | min 25° max 100° |
| Stroke | From 5 mm (0.2") |
| Input signal | 4-20 mA DC |
| Air supply | 1.4-6 barg (20-85 psi) DIN/ISO 8573-1 3.2.3 Free from oil, water and moisture. |
| Air delivery | 7 Nm ³ /h @ 6 bar / 4.12 SCFM @ 87 psi |
| Air consumption | 0.120 Nm ³ /h @ 6 bar / 0.071 SCFM @ 87 psi |
| Air connections | 1/4" NPT |
| Cable entry | 2x M20x1.5 or 1/2" NPT |
| Electrical connections | Screw terminals 2.5 mm ² /AWG14 |
| Linearity | <0.4% |
| Repeatability | <0.5% |
| Hysteresis | <0.3% |
| Dead band | 0.1-10% adjustable |
| Display | Graphic, view area 15 x 41 mm (0.6 x 1.6") |
| UI | 5 push buttons /single push button |
| CE directives | 2014/30/EU, 2014/35/EU, 2014/34/EU |
| Voltage drop, w/o HART | 8 V |
| Voltage drop, with HART | 9.4 V |
| Enclosure | IP66 |
| Material | Die-cast Aluminum |
| Surface treatment | Powder coating |
| Temperature range | -20°C to 80°C (-4°F to 176°F) -40°C to +80°C (Low temp version) |
| Weight | 1.8 kg (4 lbs) |
| Mounting position | Any |
| Communication protocols | Hart, Profibus PA, Foundation Fieldbus |

| <i>Mechanical switches</i> | |
|----------------------------|--------------------------------|
| Type | SPDT |
| Size | V3 |
| Rating | 3 A/250 VAC / 1A@30VDC |
| Temperature range | -40°C to 80°C (-40°F to 176°F) |

| <i>NAMUR sensors</i> | |
|----------------------|---------------------------------|
| (NJ2-V3-N) | |
| Type | Proximity DIN EN 60947-5-6:2000 |
| Load current | 1 mA ≤ I ≤ 3 mA |
| Voltage range | 8,2 VDC |
| Hysteresis | 0.2% |
| Temperature range | -25°C to 80°C (-13°F to 176°F) |

| <i>Proximity switches</i> | |
|---------------------------|--------------------------------|
| Type | SPDT |
| Rating | 0.4 A @ 24 VDC, Max 10 W |
| Operating time | Max 1.0 ms |
| Max voltage | 200 VDC |
| Contact resistance | 0.2 Ω |
| Temperature range | -40°C to 80°C (-40°F to 176°F) |

| <i>Slot NAMUR switches</i> | |
|----------------------------|---|
| (SJ2-SN, SJ2-N) | |
| Type | Proximity DIN EN 60947-5-6:2000 |
| Load current | 1 mA ≤ I ≤ 3 mA |
| Voltage | 8,2 VDC |
| Hysteresis | 0.2% |
| Temperature range | -25°C to 80°C (-13°F to 176°F) SJ2-N -40°C to 80°C (-40°F to 176°F) SJ2-SN |

| <i>4-20 mA transmitter</i> | |
|----------------------------|----------------|
| Supply | 11-28 VDC |
| Output | 4-20 mA |
| Resolution | 0.1% |
| Linearity full span | +/-0.5% |
| Output current limit | 30 mA DC |
| Load impedance | 800 Ω @ 24 VDC |

14. Dimensional Drawing

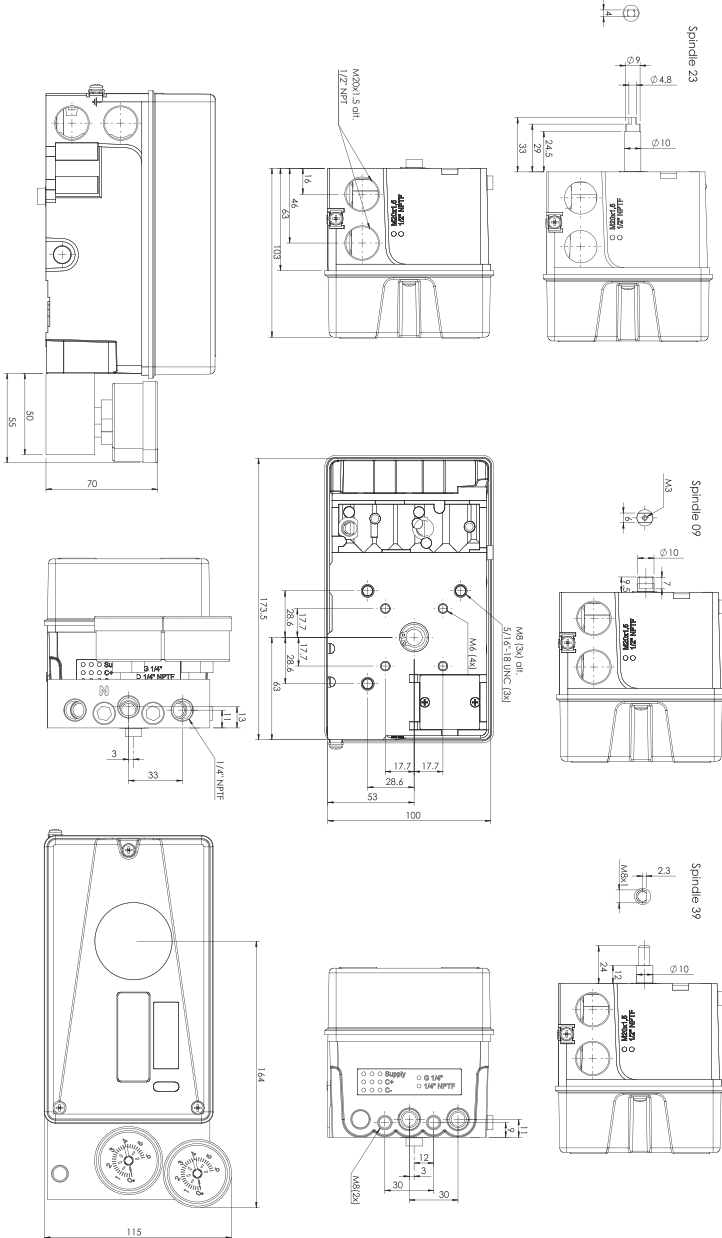

15. Spare parts

| No | Part no | Description |
|----|-------------|--|
| 1 | D4-SP37PVA | Black cover incl. screws and flat indicator |
| 1 | D4-SP37FWA | White cover incl. screws and flat indicator |
| 2 | D4-SP40 | Internal cover incl. screws |
| 4 | 3-SXX | Spindle adapter (XX = 01, 02, 06, 26, 30, 36...) |
| 5 | D4-SP05-09 | S09 shaft compl. incl. gear wheel, friction clutch, spring |
| 5 | D4-SP05-21 | S21 shaft compl. incl. gear wheel, friction clutch, spring |
| 5 | D4-SP05-23 | S23 shaft compl. incl. gear wheel, friction clutch, spring |
| 5 | D4-SP05-39 | S39 shaft compl. incl. gear wheel, friction clutch, spring |
| 6 | D2-SP50 STD | Air relay complete, incl. cable, seal, screws |
| 6 | D2-SP50 LT | Air relay complete for Low temp, incl. cable, seal, screws |
| 7 | D4-SP08 | Potentiometer compl. incl. spring, bracket, cable |
| 8 | 3-SP37HR | PCB LCD, 5 buttons, assembly |
| 8 | AV-SP080 | PCB LCD only, assembly |
| 9 | D4-SP80-3S | PCB mother board 4-20 mA / HART (For D22 version) |
| 9 | D4-SP80-1S | Single button PCB mother board 4-20 mA / HART |
| 9 | D4-SP80-PS | PCB mother board Profibus PA |
| 9 | D4-SP80-FS | PCB mother board Fieldbus |
| 10 | D4-SP84-2 | D20 pressure sensor assembly complete (Optional) |
| 11 | D4-SPGB | Bag with screws, O-rings, seals, pair of sintered brass silencers, cable gland |
| 12 | D4-SP940N2 | Gauge block NPT, complete incl. screws, seals, 2 gauges / SST, Brass |
| 13 | D4-SP081 S | Limit switches Mechanical SPDT compl. |
| 13 | D4-SP081 N | Limit switches NAMUR V3 P&F NJ2-V3-N compl. |
| 13 | D4-SP081 P | Limit switches Proximity SPDT compl. |
| 13 | D4-SP081 5 | Limit switches NAMUR slotted P&F SJ2-SN compl. |
| 13 | D4-SP081 6 | Limit switches NAMUR slotted P&F SJ2-N compl. |

Note: Replacement of certified spare parts require proper qualification and knowledge of applicable standards.

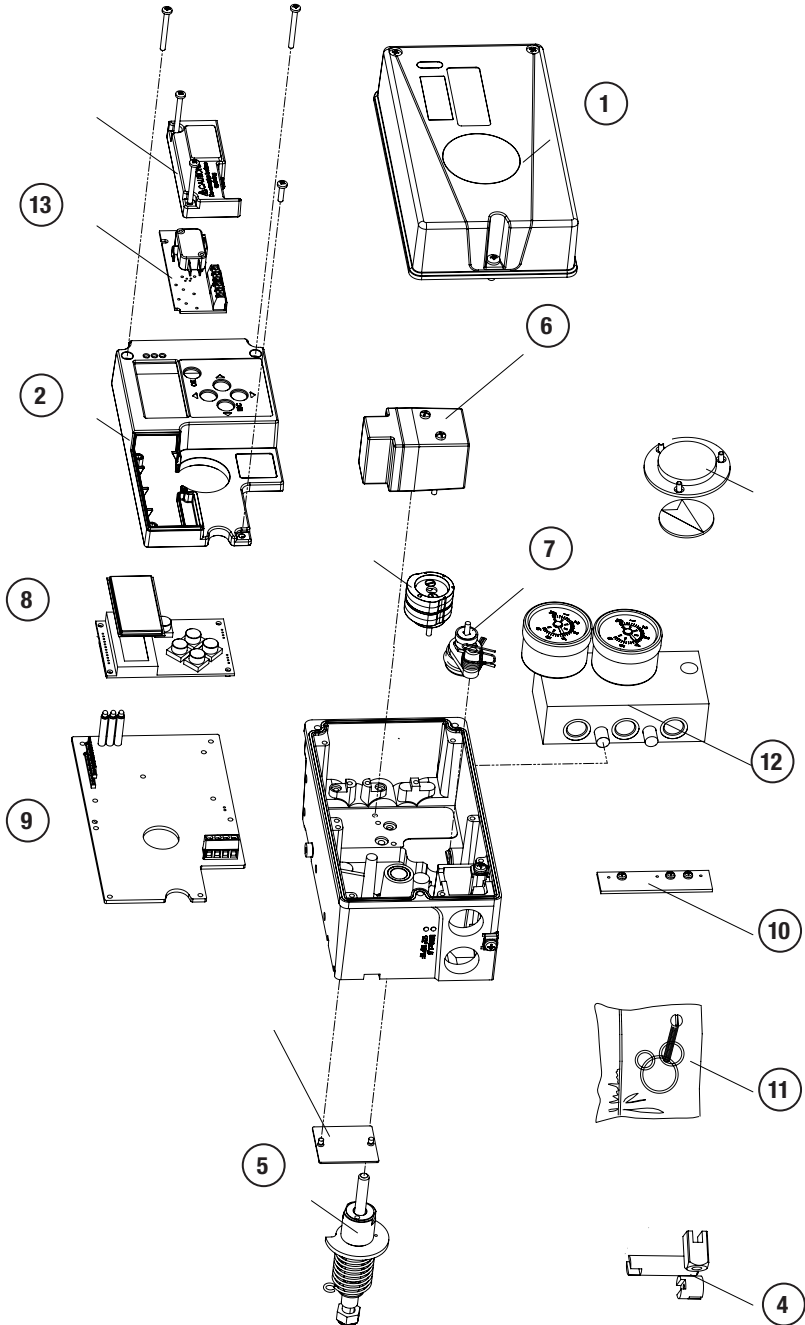

16. Declaration of Conformity



EU Declaration of Conformity

We, **PMV Automation AB, Korta Gatan 9, SE-171 54 Solna**, declare under our sole responsibility that, our product,

D20 – Digital Valve Positioner

is in conformity with the following harmonized legislation:

2014/30/EU – Electromagnetic compatibility (EMC) directive, based on conformity with the requirements of harmonized standards:

- EN 61000-6-2:2005
- EN 61000-6-2:2005/AC:2005,
- EN 61000-6-4:2007, and
- EN 61000-6-4:2007/A1:2011

The product is also evaluated by PMV to comply with the following standards:

- EN IEC 61000-6-2:2019, and
- EN IEC 61000-6-4:2019

2014/35/EU – Low voltage (LV) directive¹, based on conformity with the requirements of harmonized standards:

- EN 60204-1:2018

2014/34/EU – Equipment for explosive atmospheres (ATEX) directive, based on conformity with the requirements of harmonized standards:

- Intrinsically safe Ex ia EN IEC 60079-0:2018, and
- EN 60079-11:2012

Conformity assessment procedures, Modul B and Mode D of the ATEX directive, have been carried out, and the following Notified Bodies attest the compliance of our product type(s) and of the quality assurance of the involved production processes respectively:

EU-type examination

Ex ia **NB 2460**
DNV Product Assurance AS
Veritasveien 1, 1363 Høvik, Norway

Quality assurance

NB 0470
NEMKO Group AS
Philip Pedersøns vei 11, 1366 Lysaker, Norway

Product marking(s)

Ⓔ II 1 G Ex ia IIC T4 Ga -40°C≤T_a≤+85°C

Certificate(s)
Presafe 17 ATEX 11142X Issue 1

Model code(s)

D2xAxxx-xxxxxx-xxxxxx

Nemko 03ATEX4122QP

Signed for and on behalf of: **PMV Automation AB**

Ulf Nylund
Quality Manager

.....
Solna, Sweden,
2024-10-02

¹The directive, 2014/35/EU, on the safety of low voltage equipment only applicable if the Digital Valve Positioner itself is outside the potentially explosive atmosphere, but it has an impact on the safety.
²The certificate of the quality assurance system of the manufacturing process.

17. Control Drawing

D30/D20 series terminal configuration

(Position J, J=4 or 5)
(Position J, J=4 or 5)

4-20mA input signal Pin 1 and 2
Position J, J=4 or 5

Profibus PA / Fieldbus Foundation Pin 1 and 2
Position J, J=4 or 5

Position J, J=4 or 5

HAZARDOUS AREA UNCLASSIFIED AREA

1+ POSITIONER
U 5 ± 28 V
I 5 ± 83 mA
C 5 ± 11.3 nF
L 5 ± 10 µH

2- Safety Barrier

HAZARDOUS AREA UNCLASSIFIED AREA

1+ POSITIONER
U 5 ± 28 V
I 5 ± 83 mA
C 5 ± 11.3 nF
L 5 ± 10 µH

2- Safety Barrier

HAZARDOUS AREA UNCLASSIFIED AREA

3+ POSITIONER
U 5 ± 28 V
I 5 ± 83 mA
C 5 ± 11.3 nF
L 5 ± 10 µH

4- Safety Barrier

HAZARDOUS AREA UNCLASSIFIED AREA

4-20mA Output signal Pin 3 and 4
(Position J, J=4 or 5) AND (Position K; K≠X)

HAZARDOUS AREA UNCLASSIFIED AREA

3+ POSITIONER
U 5 ± 28 V
I 5 ± 83 mA
C 5 ± 11.3 nF
L 5 ± 10 µH

4- Safety Barrier

HAZARDOUS AREA UNCLASSIFIED AREA

Remote Unit

Position GG; GG≠X
(Where X any character) (Unit has no switches)

HAZARDOUS AREA UNCLASSIFIED AREA

POSITIONER
Po 0.38W

8 Potentiometer of FS unit

9

10

Requires shielded cable less than 10 m or 30 feet

Potentiometer unit needs an appropriate and compatible Certification for the Hazardous area

Allowed FS units are: F5ISxx-xxx-P07-xxP/xxxx
F5ISxx-xxx-P18-xxP/xxxx ; F5ISxx-xxx-P27-xxP/xxxx

D30 Model code

1 2 3 4 5 6 7 8 9 10 11 12 13 14 15 16 17 18 19

A A B C D E - F G H I J - K L M N

Position D designates certification

Position N designates communication protocol

Position J designates switch type

Position H designates indicator type

| | |
|---|----------|
| D | General |
| E | ATEX |
| A | IEC |
| F | FM/IS/NI |

| | |
|---|--------|
| B | Imetro |
| K | Ksiba |
| T | TR-CLU |
| N | NEPSI |

Pos.B

switches

HAZARDOUS AREA UNCLASSIFIED AREA

| | |
|---------|----------------------|
| 5 or 8 | Switch U, J, P and L |
| 5 or 9 | According to table |
| 7 or 10 | to isolate |

Safety Barrier

terminal 7 and 10 not used for Namur Switches
Terminal 5-7 lower switch
Terminal 8-9 upper switch

model code position K

| Note | SWITCH | Type | Cr/F | LUH | UV | I mA | Pi n/W | MH Temp | T4 | T5 | T6 | model code position B | | A | E | F | |
|------|--------|----------------|------|-----|----|------|--------|---------|----|----|-----|-----------------------|----|----|----|----|----|
| 5 | 2.4 | SZ-SH | 30 | 100 | 16 | 25 | 34 | 40 | 96 | 68 | 56 | 100 | GG | GG | GG | GG | GG |
| 6 | 1.4 | SZ-N | 30 | 100 | 16 | 25 | 34 | 25 | 96 | 68 | 56 | 100 | GG | GG | GG | GG | GG |
| 7 | 1 | SCZ-NGN | 130 | 150 | 16 | 25 | 34 | 25 | 95 | 67 | 55 | 100 | GG | GG | GG | GG | GG |
| 8 | 1 | SCZ-NGE | 130 | 150 | 16 | 25 | 34 | 25 | 95 | 67 | 55 | 100 | GG | GG | GG | GG | GG |
| 9 | | MISC: | | | | | | | | | | | | | | | |
| G | 3.4 | INZ-VEN | 40 | 50 | 16 | 25 | 34 | 25 | 96 | 68 | 56 | 100 | GG | GG | GG | GG | GG |
| H | | IDENT IDENTITY | 1 | 1 | 20 | 45 | 315 | 40 | 78 | 60 | 45 | | GG | GG | GG | GG | GG |
| I | | IDENT IDENTITY | 1 | 1 | 20 | 45 | 315 | 40 | 78 | 60 | 45 | | GG | GG | GG | GG | GG |
| U | 3.4 | INCN-V240 | 100 | 100 | 12 | 25 | 34 | 25 | 73 | 88 | 100 | 100 | GG | GG | GG | GG | GG |

note 1 ATEX IEC: Higher U, I and P with lower ambient temperatures are allowed see Certificate PIB 99 ATEX 2219 X or IECEx PIB 11.0091 X
note 2 ATEX IEC: Higher U, I and P with lower ambient temperatures are allowed see Certificate PIB 00 ATEX 2049 X or IECEx PIB 11.0092 X
note 3 ATEX IEC: Higher U, I and P with lower ambient temperatures are allowed see Certificate PIB 00 ATEX 2032 X or IECEx PIB 11.0021 X
note 4 cFMUs: For safe S installation and alternative safety values see FM control drawing: 116-01655 - and for NI installation without associated apparatus see control drawing: 116-0155E.

ATEX, IEC, cFMus

Warnings:
Substitution of components may impair suitability for hazardous (Classified) locations.
Do not disconnect equipment unless area is known to be non-hazardous.
To prevent ignition of flammable or combustible atmospheres, disconnect power before servicing, or read, understand and adhere to the manufacturer's line maintenance procedures.
Avoid intensive rubbing or brush charging of plastic parts in combustible atmospheres.

Avertissement:
La substitution de composants peut compromettre la sécurité intrinsèque.
Ne déconnectez pas l'équipement tant que la zone n'est pas dangereuse.
Pour éviter l'inflammation des atmosphères inflammables ou combustibles, débranchez l'alimentation avant de procéder à l'entretien, ou, lire, comprendre et respecter les procédures de maintenance en direct du fabricant.
Éviter de frotter ou de charger à la brosse des pièces en plastique dans des atmosphères combustibles.

Special condition for safe use see Sheet page 2

Scheduled drawing

No modification permitted without reference to notified body

Control Drawing

DESCRIPTION: UNCLASSIFIED AREA

MATERIAL: UNCLASSIFIED AREA

UNDESIGNED TOLERANCES ACCORDING TO: UNCLASSIFIED AREA

PROJECTION: UNCLASSIFIED AREA

SCALE: UNCLASSIFIED AREA

DATE: UNCLASSIFIED AREA

DRW: UNCLASSIFIED AREA

SCALE: UNCLASSIFIED AREA

DATE: UNCLASSIFIED AREA

PMV Positioners D30/D20

PMV Automation AB
KORTA GATAN 9 SE-171 84 SÖDRA SVEBEN - Tel: +46(0)8 555 106 00 - www.pmv.se

Sheet 1.2

2017-12-11

FM only

HAZARDOUS AREA:
 Class I, II, Division 1, Group A, B, C, D, T4
 Class I, Zone 0, 1, AEx, Ia, IIC, T4
 Class I, Division 2, Group A, B, C, D, T4
 Class II, Zone 0, 1, AEx, Ia, IIC, T4
 Class II, Div. 1&2, T4

INSTALLATION NOTES:

- Control equipment connected to the associated apparatus shall not use or generate more than 250Vrms or Vdc.
- Associated apparatus manufacturer's installation drawing shall be followed when installing this equipment.
- Run shielded interconnection cable with shield connected to FM approved associated apparatus ground.

The intrinsically safety entity concept:

Allows the interconnection of two intrinsically safe devices FM approved with entity parameters not specifically examined in combination as a system when:
 Uo or Voc or Vi ≤ Vmax, Io or Iac or Ii ≤ Imax, Po ≤ Pi, Co or Co ≥ Ci + Ccable, La or Lo ≥ Li + Lcable.

The non-incendive field wiring concept:

Allows the interconnection of two field wiring apparatus with associated non-incendive field apparatus, using any of the wiring methods permitted for non-hazardous (undclassified) locations when:
 Uo or Voc or Vi ≤ Vmax, Io or Iac or Ii ≤ Imax, Po ≤ Pi, Co or Co ≥ Ci + Ccable, La or Lo ≥ Li + Lcable.

The non-incendive:

- Use IS values as general (Vmax = Ui, Imax = Ii) except for following:
- Nameplate values for the associated apparatus shall be used for Vmax, Imax and Ii.
- Vmax = 25V, Imax is not required for this current controlling circuit
- Proximity Switch (Pos Kc-F)
 Vmax = 30V, Imax = 500mA
- 4-20mA input signal (Pin 1 and 2)
 Vmax = 30V, Imax = 40mA
- 4-20mA Output signal (Pin 3 and 4)
 Vmax = 30V, Imax is not required for this current controlling circuit

For division 1 installations:

- The configurations of associated apparatus shall be FM approved under entity concept.
- Division 1 installations should be in accordance with ASH/ISA RP12.06.01.
- Installation of intrinsically safe systems for hazardous (classified) locations* and the national electrical code (ANSI/NFPA 70).

For division 2 installations:

- Using non-incendive field wiring concept, the associated apparatus shall be FM approved under entity concept or non-incendive field wiring concept.
- The associated apparatus is not required to be FM approved under entity concept or non-incendive field wiring concept if the unit is installed in accordance with the national electrical code (ANSI/NFPA 70) for division 2, wiring methods excluding non-incendive field wiring.

ATEX IEC
 (Including IEC related Certificates)

Special Conditions for Safe Use

The enclosure of PMV D30/D20 Intrinsically safe version is made of aluminum and any impact or friction caused by external objects shall be avoided in the application.

The intrinsic safe circuits D30/D20 is insulated from earth and complies with the dielectric strength test of 500 V ac.

The surface area of the plastic parts on the cover exceeds the limits specified in EN 60079-0 for IIG (EPL Ga) for gas group IIC and intensive rubbing or brush cleaning should be avoided when used in an IIC explosive atmosphere.

The cable connection of the Remote Unit with the D30/D20 unit shall be type A or B in accordance with EN 60079-25. The cable must be adequately mechanically protected in all instances and have a temperature rating for the ambient temperature range at the site.

General requirements for units with 4 conduit openings and NPT threading.
Model code position D-N and Position E= 4 or F

Cable glands must be used when installing.
 Cable glands may not be installed on the same level.
 A maximum of two cable glands may be used, the unused openings must be plugged by supplied blanks or other suitable blanks.

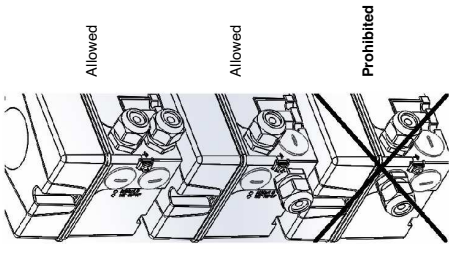

Sheet 2.2

| | | | |
|-----------------|---|-------------------|------------|
| DESCRIPTION | MATERIAL | DIMENSION | ANIMATION |
| Control Drawing | UNSPECIFIED TOLERANCES ACCORDING TO SURFACE | | |
| FILE NO. | | | |
| | | PROJECTION EUROPA | |
| | | DR BY | Rev. |
| | | LRW | 4 |
| | | SCALE | — |
| | | DATE | 2017-12-11 |
| | | DRAWING NO. | |
| | | | D4-086C |

Scheduled drawing
 No modification permitted without reference to National Body

PMV Positioners
D30/D20

Flowserve
 PM Positioners

PMV Automation AB

KORTA GATAN 9 SE-171 84 SOMMA SVEDEEN - Tel: +46(0)8 555 108 00 - www.pmv.se

This document must not be copied without our written permission and the contents thereof must not be imparted to a third party nor be used for any unauthorized purpose. Copying without our written permission is prohibited.

18. Annex: Diagnostic Alarms

| <i>Online diagnostic alarms</i> | <i>D3</i> | <i>D20/D20E</i> | <i>D22</i> | <i>D30</i> |
|--|-----------|-----------------|------------|------------|
| Actuator parts worn out | X | X | X | X |
| Auto PST failed | X | X | X | X |
| C- leakage | X | | X* | X* |
| C- pressure sensor failure | X | | X* | X |
| C+ leakage | X | | X* | X* |
| C+ pressure sensor failure | X | | X* | X |
| Calibration error | X | X | X | X |
| Control out of tune | X | X | X | X |
| CPU failure or memory failure | X | X | X | X |
| Current sensor failure | X | X | X | X |
| Deviation | X | X | X | X |
| Deviation of lower spring range | X | | X* | X* |
| Deviation of lower travel range | X | | X* | X* |
| Deviation of upper spring range | X | | X* | X* |
| Deviation of upper travel range | X | | X* | X* |
| Excessive closing force | X | | X* | X |
| Excessive number of cycles | X | X | X | X |
| Excessive number of high cutoffs | X | X | X | X |
| Excessive number of low cutoffs | X | X | X | X |
| Excessive number of piezo valve pulses | X | | | |
| Excessive opening force | X | | X* | X |
| Feedback linkage failure | X | X | X | X |
| Feedback linkage play | X* | | X* | X* |
| Foreign object in valve | X | | X* | X* |
| High air consumption | X | | | |
| High current | X | X | X | X |
| High cutoff failure | X | | X* | X* |
| High EP stress | X | X | X | |
| High friction | X | | X* | X* |
| High friction at closed position | X | | X* | X* |
| High supply pressure | X | | X* | X |
| Leakage between C+ and C- | X | | X* | X |
| Limit 1 | X | X | X | X |
| Limit 2 | X | X | X | X |
| Low available force | X | | X* | X* |
| Low CPU voltage | X | X | X | X |
| Low cutoff failure | X | | X* | X* |
| Low friction | X | | X* | X* |
| Low supply pressure | X | | X* | X |
| Manual mode | X | X | X | X |
| Out of service | X | X | X | X |
| Packing worn out | X | X | X | X |
| Position vs. pressure difference | X | | X* | X |
| Potentiometer failure | X | X | X | X |
| Potentiometer not calibrated | X | X | X | X |
| Pressure sensor disconnected | X | | X* | X |
| Seat worn out | X | X | X | X |
| Setpoint oscillation | X | X | X | X |
| Small minimum pulse parameter | X | | X* | X* |
| Spring range deviation | X | | X* | X* |
| Spring too weak to reach failsafe position | X | | X* | X* |
| Stuck valve | X | | X* | X |
| Supply pressure sensor failure | X | | X* | X |
| Temperature | X | X | X | X |
| Temperature sensor failure | X | X | X | X |
| Travel span deviation | X | | | |

* Require pressure sensor for diagnostics

Note: For more information, please check the ValveSight IOM.



FCD PNENIM0020-07-A5 – 01/26

To find your local Flowserve representative:

To find your local Flowserve representative please use the Sales Locator

System found at www.flowserve.com

Flowserve Corporation has established industry leadership in the design and manufacture of its products. When properly selected, this Flowserve product is designed to perform its intended function safely during its useful life. However, the purchaser or user of Flowserve products should be aware that Flowserve products might be used in numerous applications under a wide variety of industrial service conditions. Although Flowserve can provide general guidelines, it cannot provide specific data and warnings for all possible applications. The purchaser/user must therefore assume the ultimate responsibility for the proper sizing and selection, installation, operation, and maintenance of Flowserve products. The purchaser/user should read and understand the user instructions included with the product, and train its employees and contractors in the safe use of Flowserve products in connection with the specific application.

While the information and specifications contained in this literature are believed to be accurate, they are supplied for informative purposes only and should not be considered certified or as a guarantee of satisfactory results by reliance thereon. Nothing contained herein is to be construed as a warranty or guarantee, express or implied, regarding any matter with respect to this product. Because Flowserve is continually improving and upgrading its product design, the specifications, dimensions and information contained herein are subject to change without notice. Should any question arise concerning these provisions, the purchaser/user should contact Flowserve Corporation at any one of its worldwide operations or offices.

For more information about Flowserve Corporation, contact www.flowserve.com or call USA 1-800-225-6989.

© January 2026, Flowserve Corporation, Irving, Texas

PMV Automation AB
Korta Gatan 9
SE-171 54 SOLNA
SWEDEN
Phone: +46 (0)8-555 106 00
E-mail: infopmv@flowserve.com